

# Post-Fukushima Action Implementation at Nuclear Installations

Human and Organisational  
Factors Lessons Learnt





Human Aspects of Nuclear Safety

# **Post-Fukushima Action Implementation at Nuclear Installations**

**Human and Organisational Factors Lessons Learnt**

© OECD 2023  
NEA No. 7578

NUCLEAR ENERGY AGENCY  
ORGANISATION FOR ECONOMIC CO-OPERATION AND DEVELOPMENT

## ORGANISATION FOR ECONOMIC CO-OPERATION AND DEVELOPMENT

The OECD is a unique forum where the governments of 38 democracies work together to address the economic, social and environmental challenges of globalisation. The OECD is also at the forefront of efforts to understand and to help governments respond to new developments and concerns, such as corporate governance, the information economy and the challenges of an ageing population. The Organisation provides a setting where governments can compare policy experiences, seek answers to common problems, identify good practice and work to co-ordinate domestic and international policies.

The OECD member countries are: Australia, Austria, Belgium, Canada, Chile, Colombia, Costa Rica, the Czech Republic, Denmark, Estonia, Finland, France, Germany, Greece, Hungary, Iceland, Ireland, Israel, Italy, Japan, Korea, Latvia, Lithuania, Luxembourg, Mexico, the Netherlands, New Zealand, Norway, Poland, Portugal, the Slovak Republic, Slovenia, Spain, Sweden, Switzerland, Türkiye, the United Kingdom and the United States. The European Commission takes part in the work of the OECD.

OECD Publishing disseminates widely the results of the Organisation's statistics gathering and research on economic, social and environmental issues, as well as the conventions, guidelines and standards agreed by its members.

*This work is published under the responsibility of the Secretary-General of the OECD. The opinions expressed and arguments employed herein do not necessarily reflect the official views of the member countries of the OECD or its Nuclear Energy Agency.*

## NUCLEAR ENERGY AGENCY

The OECD Nuclear Energy Agency (NEA) was established on 1 February 1958. Current NEA membership consists of 34 countries: Argentina, Australia, Austria, Belgium, Bulgaria, Canada, the Czech Republic, Denmark, Finland, France, Germany, Greece, Hungary, Iceland, Ireland, Italy, Japan, Korea, Luxembourg, Mexico, the Netherlands, Norway, Poland, Portugal, Romania, Russia (suspended), the Slovak Republic, Slovenia, Spain, Sweden, Switzerland, Türkiye, the United Kingdom and the United States. The European Commission and the International Atomic Energy Agency also take part in the work of the Agency.

The mission of the NEA is:

- to assist its member countries in maintaining and further developing, through international co-operation, the scientific, technological and legal bases required for a safe, environmentally friendly and economical use of nuclear energy for peaceful purposes;
- to provide authoritative assessments and to forge common understandings on key issues, as input to government decisions on nuclear energy policy and to broader OECD policy analyses in areas such as energy and sustainable development.

Specific areas of competence of the NEA include the safety and regulation of nuclear activities, radioactive waste management and decommissioning, radiological protection, nuclear science, economic and technical analyses of the nuclear fuel cycle, nuclear law and liability, and public information. The NEA Data Bank provides nuclear data and computer program services for participating countries.

This document, as well as any data and map included herein, are without prejudice to the status of or sovereignty over any territory, to the delimitation of international frontiers and boundaries and to the name of any territory, city or area.

Corrigenda to OECD publications may be found online at: [www.oecd.org/about/publishing/corrigenda.htm](http://www.oecd.org/about/publishing/corrigenda.htm).

### © OECD 2023

You can copy, download or print OECD content for your own use, and you can include excerpts from OECD publications, databases and multimedia products in your own documents, presentations, blogs, websites and teaching materials, provided that suitable acknowledgement of the OECD as source and copyright owner is given. All requests for public or commercial use and translation rights should be submitted to [neapub@oecd-nea.org](mailto:neapub@oecd-nea.org). Requests for permission to photocopy portions of this material for public or commercial use shall be addressed directly to the Copyright Clearance Center (CCC) at [info@copyright.com](mailto:info@copyright.com) or the Centre français d'exploitation du droit de copie (CFC) [contact@cfcopies.com](mailto:contact@cfcopies.com).

Cover photos: Emergency exercise 1 and 2 (KINS); Validation of the filtered containment venting system (CSN).

## Acknowledgements

This report is the product of a multi-year effort by a task group of the Nuclear Energy Agency (NEA) Working Group on Human and Organisational Factors (WGHOF). The task group comprised the following individuals:

- Lars Axelsson (Swedish Radiation Safety Authority [SSM]);
- Yun Hyung Chung (Korea Institute of Nuclear Safety [KINS]);
- Nicolas Dechy (Institut de Radioprotection et de Sûreté Nucléaire [IRSN]);
- Cesar de la Cal Losada (Centrales Nucleares Almaraz-Trillo);
- David Desaulniers (Task Lead, US Nuclear Regulatory Commission [NRC]);
- Suzanne Dolecki (Canadian Nuclear Safety Commission [CNSC]);
- Benito Gil (Consejo de Seguridad Nuclear [CSN]);
- Lisa Hagen (CNSC);
- Carine Hebraud (Autorité de Sûreté Nucléaire [ASN]);
- Hiroyasu Ito (Japan Nuclear Safety Institute [JANSI]);
- Wondea Jung (Korea Atomic Energy Research Institute [KAERI]);
- Mohand Saïd Khemliche (IRSN);
- Jitae Kim (KINS);
- Jan Kubicek (UJV);
- Ryuji Kubota (Japan Nuclear Regulatory Authority [JNRA]);
- Dhong Hun Lee (KINS);
- Salvatore Massaiu (OECD Halden Reactor Project);
- Hiroko Takada (JNRA);
- Daniel Tasset (IRSN).

The US NRC served as the lead organisation. In addition, the task group received outstanding support from the NEA, notably from Monica Haage, Pascale Bourassa, Kamishan Martin and Natalie Bonilla.

The WGHOF extends its appreciation to all these individuals and their organisations for their generosity in contributing their time and expertise to this effort.



## Table of contents

<b>List of abbreviations and acronyms</b> .....	7
<b>Executive summary</b> .....	9
Chapter 1. <b>Introduction</b> .....	13
Motivation .....	13
Project overview .....	13
Participating countries/organisations .....	14
Chapter 2. <b>Phase 1 summary</b> .....	15
Phase 1: Information request.....	15
Insights from Phase 1 .....	17
Potential HOF implications and challenges .....	18
Chapter 3. <b>Phase 2 summary</b> .....	21
Issuance of requests for lessons learnt .....	21
Instructions for submitting lessons learnt .....	21
Lessons learnt summaries and examples.....	24
Insights from Phase 2 .....	38
Chapter 4. <b>Conclusions</b> .....	43
Chapter 5. <b>Recommendations</b> .....	45
<b>References</b> .....	47
<b>List of appendices</b>	
A: Regulatory Authority Responses to the Phase 1 Information Request - Summaries of Actions Taken and Questionnaire Responses Regarding Human and Organisational Factors Addressed by these Actions.....	49
B: Responses to Phase 2 Information Request – Human and Organisational Factors Lessons Learnt Implementing Post-Fukushima Actions.....	51
<b>List of figures</b>	
1. Summary of the three project phases .....	14
2. Remote Automated Gamma Monitoring Station.....	26
3. Sequence of expected failures and required actions in SBO scenario .....	27
4. Mobile Diesel Generator 4 x 352 kW (one per unit).....	28
5. Conceptual diagram of a phased approach in accident response .....	29
6. Safety measures to enhance third layer of defence in depth for ABWR.....	30
7. Example of improvement of external communication .....	31
8. MACST core cooling strategies .....	34
9. Relation between procedures .....	35

10. 3.2 MW mobile diesel generator (Korea).....	35
11. Validation of the filtered containment venting system (1).....	37
12. Validation of the filtered containment venting system (2).....	37
13. Applicability of lesson learnt to on-site and off-site activities .....	39
14. Applicability of lesson learnt to work location.....	39
15. Applicability of lesson learnt to job categories.....	39
16. Applicability of lesson learnt to human and organisational factors topical areas.....	40

### List of tables

1. Country participation in task implementation .....	14
2. Summary of Phase 1 questionnaire topics and subtopics .....	15
3. List of MACST procedures .....	34



## List of abbreviations and acronyms

ABWR	Advanced boiling water reactor
AC	Alternating current
ASN	Autorité de sûreté nucléaire (France)
CANDU	Canada Deuterium Uranium
CEZ	Czech Energy Company
CNSC	Canadian Nuclear Safety Commission
COG	CANDU Owner's Group
CRD	Control rod drive
CSN	Consejo de Seguridad Nuclear (Spanish Nuclear Safety Council)
CSNI	Committee for the Safety of Nuclear Installations (NEA)
DAM	Diverse and mobile
DC	Direct current
DG	Diesel generator
ECS	Évaluation complémentaire de sûreté
EDMG	Extensive Damage Mitigation Guidelines
ELAP	Extended loss of AC power
EMC	Emergency management centre
EME	Emergency mitigating equipment
EOP	Emergency operating procedures
ERO	Emergency response organisation
ESCS	Emergency satellite communication system
FCVS	Filtered containment venting system
FEPC	Federation of Electric Power Companies
FLEX	Diverse and flexible coping strategies
FSAR	Final safety analysis report
HF	Human factors
HOF	Human and organisational factors
HOP	Human and organisational performance
HP	High pressure
HPAC	High pressure alternative cooling (pump)
HVAC	Heating, ventilation, air conditioning
HX	Heat exchanger

ICS	Incident command system
IMS	Incident management system
JANSI	Japan Nuclear Safety Institute
KAERI	Korea Atomic Energy Research Institute
KHNP	Korea Hydro and Nuclear Power Co. Ltd.
KINS	Korea Institute of Safety
LAN	Local area network
LUHS	Loss of ultimate heat sink
MACST	Multi-barrier Accident Coping Strategy
MDG	Mobile diesel generator
MOG	MACST operating guides
MUWC	Makeup water condensate (pump)
MW	Megawatt
NEA	Nuclear Energy Agency
NRC	Nuclear Regulatory Commission (United States)
OECD	Organisation for Economic Co-operation and Development
OFC	Off-site centre
PCV	Pressure containment vessel
PHS	Personal handy phone system (not nuclear specific term)
PSA	Probabilistic safety assessment
R/B	Reactor building
RHR	Residual heat removal (system)
SAMG	Severe accident management guideline
SBO	Station black out
SD	Shut down
SLC	Standby liquid control (system)
SRV	Safety relief valve
SSM	Swedish Radiation Safety Authority
UJV	Czech Nuclear Power Engineering Company
URI	Unified RASCAL (Radiological Assessment System for Consequence Analysis) Interface
US	United States
V&V	Verification and validation
WebEOC	Web-based emergency operating centre
WGHOE	Working Group on Human and Organisational Factors (NEA)

## Executive summary

On 11 March 2011, the Great East Japan Earthquake occurred off the coast of Honshu Island, resulting in a large tsunami causing widespread devastation across Japan and in particular at the Fukushima Daiichi Nuclear Power Plant. In the aftermath of the Fukushima Daiichi accident, nuclear regulators, industry organisations, and operating companies across the globe began the process of understanding the lessons learnt from the accident and planning actions to strengthen preparedness and the capabilities to respond to and mitigate the effects of such extreme external events. The actions, both within and across these plans, are diverse and include new or modified organisations, procedures, training, and equipment. Although many of these actions leverage new equipment or technologies, these enhancements typically continue to rely on the ability of plant staff to make sound and timely decisions and to complete assigned actions within a limited amount of time. As a result, human and organisational factors are central to realising the intended benefits of the many post-Fukushima enhancements that have been implemented or remain in progress.

The NEA Working Group on Human and Organisational Factors (WGHOFF) task described in this report began in 2016 with the following primary objectives:

- (1) Gathering the lessons learnt (positive and negative) related to human and organisational factors (HOF) that are being gained from implementing the actions that many regulatory authorities and nuclear facility operators around the world are taking to strengthen their ability to respond to events like those experienced at the Fukushima Nuclear Power Plant.
- (2) Sharing these lessons learnt broadly (e.g. with nuclear facility operating companies, technical support organisations, research institutions, and regulatory authorities) so that they can be used to facilitate and enhance these efforts going forward.

This report addresses the second objective by including, as appendices, the submissions and lessons learnt gathered during this initiative.

The effort comprised two phases of information collection. In Phase 1, the WGHOFF issued information requests to nuclear regulatory authorities to obtain written summaries and questionnaire responses concerning the post-Fukushima requirements and guidelines that had been issued in their country and the actions that had been taken towards enhancing mitigation of extreme external events and management of severe accidents. In both the summaries and the questionnaire, the focus was on the human and organisational factors of the activities, requirements, and guidelines. The Phase 2 information request was directed towards nuclear facility licensees and used a standardised template to elicit short summaries of HOF lessons learnt as a result of the implementation of post-Fukushima actions.

Phase 1 of the information collection was highly successful, resulting in a compendium of summaries from regulatory authorities in seven countries (Appendix A) that describes the breadth and diversity of the post-Fukushima actions, with an emphasis on the human and organisational aspects. The summaries also point to the applicable requirements and guidelines. Each summary is accompanied by questionnaire responses that draw the relationship between the specific actions described in the summaries and each of ten topical areas concerning human and organisational factors.

The Phase 1 responses indicated that in many cases the actions taken in response to the Fukushima Nuclear Power Plant accident went beyond capabilities for response to extreme external events to include enhancements to severe accident management and capabilities for response to loss of large areas of the plant due to fire or explosion. These broad-based responses reflect the interrelated and complementary nature of these capabilities and suggest that improvements in the flexibility and efficiency of accident mitigation may be realised through the

enhancements to, and integration of, these programmes. The Phase 1 responses revealed that the planned enhancements in each country included the addition of new and additional equipment for accident mitigation. While the approaches varied from country to country in terms of relative emphasis on installed vs portable equipment, nearly all the enhancements to mitigation capabilities relied on human action to effect the mitigation strategies. These Phase 1 results confirmed the importance of understanding the HOF associated with these enhancements and the potential value of HOF lessons learnt during the development, validation, and deployment of these enhancements.

Phase 2 of the information collection produced a compendium of 40 lesson learnt submissions (Appendix B) describing specific implementation activities that had been undertaken and the insights gained in the process. These submissions bring to life the actions and requirements described in responses to the Phase 1 information collection, including some of the challenges that were encountered and overcome in the process. One limitation of the Phase 2 responses was that they frequently focused on the action that was taken without substantive discussion of related HOF lessons learnt during implementation. Additionally, given the small sample size of lessons learnt and because respondents selected the lessons learnt to submit (i.e. the sample is small and non-random), the reader is cautioned against inferring that the sample is representative of the population of all HOF lessons learnt through implementation of post-Fukushima actions. Nevertheless, the Phase 2 results suggest some possible themes.

Nearly all the lessons learnt were characterised by the submitters as applicable to on-site response in comparison to roughly half being characterised as applicable to off-site activities. The results suggest a greater emphasis on on-site activities, such as prevention of core damage, relative to mitigation of off-site consequences from radiological releases. The distribution is not surprising when viewed from a perspective that it is preferable to prevent an accident than mitigate its consequences. By contrast, it was interesting to find that when considering plant locations to which the lessons learnt applied, the preponderance were applicable to the emergency operations facility. A smaller number were applicable to the main control room, technical support centre, and other local control stations, though among these other locations the number of applicable lessons learnt were roughly equal. These results would seem to underscore that whereas under design-basis emergency operations the main control room is the focal point, under conditions of response to extreme external events and severe accidents, a much broader range of plant facilities and locations become prominent in the response. A similar pattern was observed when examining the applicability of lessons learnt to job categories, with other categories of personnel being the subject of lessons learnt as often, and in some cases more often, than main control room operators. Examining the lessons learnt by the topic addressed, it emerged that the lessons learnt were most often applicable to mitigation strategies, emergency response facilities, and emergency response plans. Other procedures and guidelines, communications, and training were also commonly identified as topics addressed by the lessons learnt

In light of the information collected in Phases 1 and 2, this report discusses the central role of human and organisational performance in mitigating extreme external events and the management of severe accidents. The report also addresses the importance of validating the ability to perform these actions, and the challenges associated with performing such validations with fidelity to the conditions likely to be present during such events. The report concludes with four recommendations:

1. Explore the contents of Appendix A and use the information as a resource (e.g. identification of alternative tools, methods, and strategies) to inform current and future efforts pertaining to the mitigation of extreme events and management of severe accidents. Additionally, the report proposes a systemic human, technology and organisation (HTO) approach to implementing post-Fukushima actions such that the interactions of humans, technology and organisational factors are considered in an integrated manner, as it could prove useful in gaining the full benefit of these efforts.
2. Explore the contents of Appendix B to gain a deeper understanding of the material in Appendix A, consider the human and organisational factors of response to extreme external events and severe accidents, and assess the applicability of the lessons learnt to their efforts and capabilities for event mitigation and accident management.

3. Undertake initiatives that target the challenges associated with validating the actions required of individuals and organisations for the mitigation of extreme external events and severe accidents, with the aim of developing innovative and practical solutions and sharing these solutions broadly. Efforts are recommended to enhance validation for such actions at both the elemental and integrated levels.
4. Pursue initiatives, such as the effort documented in this report, that facilitate the identification and broad dissemination of insights and best practices for the HOF aspects of mitigating extreme external events and managing severe accidents.



## Chapter 1. Introduction

### Motivation

Extreme external events (e.g. floods, earthquakes) that can significantly challenge a nuclear facility's operational safety have, fortunately, been rare. The same can be said for severe accidents at nuclear facilities. However, this means that opportunities to learn from such events have been limited. Although the challenge of having few opportunities to learn from large scale events is certainly preferable to the alternative, it should not be dismissed or underestimated. The mitigation of these events, relative to design-basis accidents, depends on operators' manual actions and decisions, which are taken in highly challenging environmental and operational conditions. It is clear that providing the training and support necessary for personnel to be effective in these unique and challenging conditions will be critical to success in mitigating these events.

Following the accident at Fukushima Daiichi, nuclear regulatory authorities and operating companies in many countries established plans to assess and, as warranted, enhance their capabilities to mitigate the consequence of extreme external events and severe accidents. The NEA Working Group on Human and Organisational Factors (WGHOFF) recognised that the assessments, audits, validation tests, exercises, and drills conducted as part of the implementation of these mitigation capabilities represented a unique and significant opportunity to gain insights that can be used to help industry learn about the challenges and most effective means to implement such capabilities. Seizing upon this opportunity, the WGHOFF undertook the task of aggregating and disseminating internationally the lessons learnt from these activities with the objective of accelerating the accumulation of such experience and consequent industry learning.

### Project overview

The WGHOFF's main mission is to improve the understanding and technical basis for treating human and organisational factors in the nuclear industry in order to support the safety performance of nuclear installations and improve the effectiveness of regulatory practices in member countries. In keeping with the WGHOFF's mission, this effort to collect and disseminate lessons learnt focused on the human and organisational factors (HOF) associated with mitigation of extreme external events and severe accidents. The project was conducted in three phases:

- Phase 1: The WGHOFF task team requested regulatory authorities in seven countries in Europe, North America and Asia to provide information concerning post-Fukushima requirements, guidelines and implementation schedules that regulatory authorities issued or endorsed to improve the HOF elements of responding to extreme external events and severe accidents (i.e. those involving significant core damage). The intention was to gather the background information that the task team would require to: (1) formulate the Phase 2 solicitation for lessons learnt, (2) time the issuance of the solicitations given the country-specific implementation schedules, and (3) understand the lessons learnt provided by each participating country in the context of the requirements, guidelines, and schedules that were applicable to the source of the lessons learnt.
- Phase 2: The WGHOFF issued information requests to operating companies in the seven countries that participated in Phase 1. The requests to operating companies were for the HOF lessons learnt during their implementation of post-Fukushima actions for the mitigation of extreme external events and management of severe accidents. The

requests included a standardised template to summarise and submit the lessons learnt and participation was voluntary. Although responses identified the country of origin, respondents were requested to redact any information identifying sites.

- Phase 3: The task group analysed the lessons learnt to develop this report.

The three phases of the project are graphically summarised in Figure 1.

Figure 1. **Summary of the three project phases**

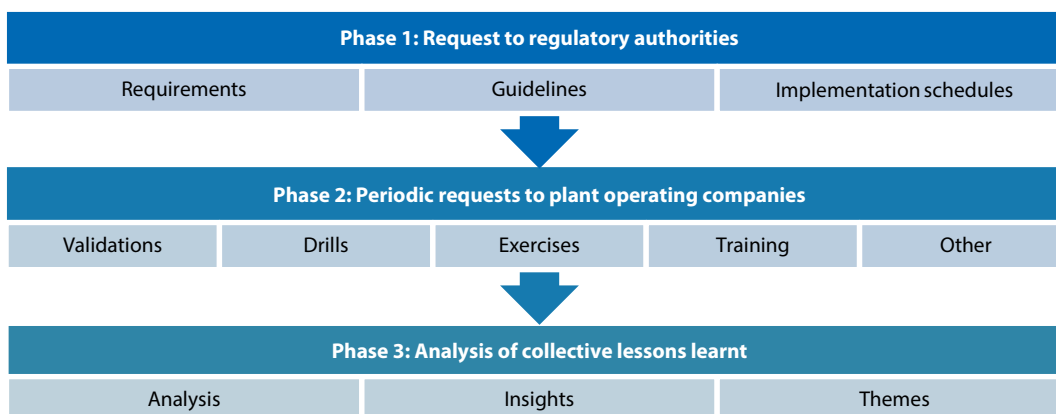

### Participating countries/organisations

Participation in this WGHOFF task was voluntary. Table 1 summarises the countries/organisations that participated in Phases 1-3 based on the availability of resources. The objective was for each country to participate in both Phase 1 and Phase 2 of the information collection to facilitate understanding of the lessons learnt in the context of national action plans, requirements and guidance. This objective was achieved with the exception of two countries that participated in only one of the two information collection phases.

Table 1. **Country participation in task implementation**

Country	Phase 1: Survey of requirements, guidelines and implementation schedules	Phase 2: Collection of human and organisational factors lessons learnt	Phase 3: Report development
Canada	X	X	X
Czech Republic		X	X
OECD Halden Reactor Project*	X	X	X
France	X	X	X
Japan	X	X	X
Korea	X	X	X
Spain	X	X	X
Sweden	X		
United States	X	X	X

The OECD Halden Reactor Project participated by providing technical support to the task group.



## Chapter 2. Phase 1 summary

### Phase 1: Information request

The Phase 1 request to regulatory authorities specifically requested that they:

- provide a brief summary of actions taken in their country since the accident at the Fukushima Daiichi Nuclear Power Plant to improve mitigation capabilities for extreme external events and severe accidents; and
- respond to a questionnaire regarding specific human and organisational factors that may have been addressed by these actions.

Respondents were asked to provide in the summary of actions an overview level perspective on the scope of actions taken, the objectives of these actions, and any important inter-relationships among these actions or between these actions and the pre-existing requirements and guidelines. The objective of the summary was to create a narrative context that helps understand the responses that the regulatory authority provided.

The objective of the questionnaire was to understand which actions described in the regulatory authority's summary of actions were intended, or are expected, to improve the ability of individuals and organisations to respond to extreme external events or severe accidents.

Each item in the questionnaire requested the regulatory authority to describe actions taken in their country in one of ten main topic areas. The ten main topic areas were developed and selected by the task group with the aim of covering the spectrum of topics where actions may have been implemented to address the human and organisational challenges presented by extreme external events and severe accidents. For each main topic area, the questionnaire included several sub-topics. The subtopics were provided as prompts or suggestions for specific information to be considered when developing a response. Table 2 summarises the ten main topic areas and subtopics of the questionnaire. For any changes described in a topical area, the regulator was asked to state their implementation schedule (either required or estimated, as applicable) and list any opportunities for gaining relevant HOF lessons learnt (e.g. related assessments, validations, audits, inspections, training, drills, and exercises).

Table 2. Summary of Phase 1 questionnaire topics and subtopics

No.	Topic	Subtopics
1.	Mitigation strategies (for maintaining or restoring core cooling, containment, and spent fuel pool cooling capabilities)	
		a. Development of new mitigation strategies
		b. Modification of current mitigation strategies
		c. Assessment and/or integration of the whole set of mitigation strategies (e.g. Extended Damage Mitigation Guidelines, FLEX Guidelines, Severe Accident Guidelines, Emergency Operating Guidelines, etc.).
		d. Addition of new procedures/guidelines for newly installed systems or components or new mobile equipment for improving mitigation capabilities
		e. Changes, if any, in strategy design, implementation, use and adherence
		f. Other actions related to mitigation strategies

Table 2. Summary of Phase 1 questionnaire topics and subtopics (cont'd)

No.	Topic	Subtopics
2.	Other procedures and guidelines (to manage other elements of event or emergency response not directly supporting the implementation of mitigation strategies)	
		a. Modification of procedures and guidelines
		b. Changes, if any, in procedure design, implementation, use and adherence
		c. Other changes or additions to procedures and guidelines
3.	Staffing	
		a. Assessment of staffing needs (numbers and roles)
		b. Changes in plans and measures to augment on-site staffing
		c. Other actions related to staffing
4.	Organisational structures, communication, decision making authorities, and safety culture	
		a. Changes, if any, in the command and control organisations for accident management, including single and multiple source term response, if applicable
		b. Others changes to organisation structures, co-ordination protocols, and guidance for decision making and communications (both internal and external). (Note: Communications equipment is addressed separately in topical area 6)
		c. Changes, if any, in the requirements or guidelines for promoting healthy safety culture
5.	Personnel qualification and training	
		a. Changes in job qualification requirements to address the need for new technical and non-technical (e.g. for managing the unexpected, stress management) knowledge and abilities
		b. Changes in training programme content to address new knowledge and ability needs
		c. Changes in training programme structure (e.g. instruction/assessment methods or frequency)
		d. Other changes to personnel qualifications or training
6.	Plant instrumentation, controls, human-system interfaces, and communications equipment	
		a. Addition or modifications to plant instrumentation and control to improve the usability or availability of information to plant staff and their ability to take control actions (e.g. spent fuel pool instrumentation, containment venting)
		b. Addition or modifications to plant communications capabilities (on-site/internal communications and communication with off-site individuals/organisations)
		c. Other changes to plant or equipment human-system interfaces to improve human performance reliability
7.	Portable equipment/tools, protective gear, and work environments	
		a. Provision of additional portable plant equipment or hand tools to support reliable human performance
		b. Design of portable plant equipment or hand tools to support reliable human performance (e.g. plug and play pipe connections, portable and installed equipment painted with some specific colour, equipment needed during a station blackout identified with fluorescent labels)
		c. Provision of additional protective gear or modifications to protective gear to support reliable human performance
		d. Modifications to work environments to support reliable human performance (e.g. emergency lighting, flood protection)
		e. Other changes to plant equipment/environments to support reliable performance of mitigation actions
8.	Work planning, technical support, and emergency response facilities	
		a. Design and implementation of new or modified on-site facilities
		b. Design and implementation of new or modified off-site facilities
		c. Changes to other facilities not previously addressed
9.	Emergency response	
		a. Changes in emergency response plans or implementation methods
		b. Changes in the drills or exercises of the emergency response plan
		c. Other changes to emergency response plans
10.	Extended (longer-term) response	
		a. Additions or modifications to plans or capabilities to address on-site staff physiological needs (e.g. food, water, sleep, hygiene) over the duration of time required to achieve a safe/stable plant state
		b. Additions or modifications to plans or capabilities to address on-site staff psychological needs (e.g. fatigue/stress management, contact with families) over the duration of time required to achieve a safe/stable plant state
		c. Additions or modifications to plans or capabilities to relieve/augment on-site staff (e.g. communication, transportation, site access)
		d. Other additions or modifications to extended response plans

The questionnaire requested the regulatory authorities to describe any actions by the regulatory authority or industry organisations in their country. Actions to be described included, but were not limited to, requirements, recommendations, demands for information or assessments, guidelines, and regulatory oversight. The directions also stated that the scope of individual and organisational performance to consider when listing actions in the responses should include, but was not limited to, actions by: (1) control room operators, (2) equipment operators or other field personnel installing/operating equipment in the field, (3) personnel to prevent or mitigate adverse effects of the environment (e.g. external flooding), (4) personnel in work control centres, technical support centres, emergency operations facilities or like facilities, (5) personnel in emergency response organisations or like organisations managing off-site radiological responses, (7) personnel in off-site organisations (e.g. local police, fire, medical personnel), (8) senior officials with decision making authority for site responses under conditions of extreme external events and severe accidents. The directions also noted that the time period to be considered for the individual/organisational actions should include the onset of the event through maintaining the plant in a safe/stable state, prior to the initiation of recovery actions.

### Insights from Phase 1

The responses from each country to the Phase 1 information request are provided as Appendix A to this report. As noted in Table 1, seven countries responded to the Phase 1 information request. Each respondent addressed the breadth of the information request noting the requirements or guidelines that had been established and the actions that had been undertaken or were planned for each of the ten topical areas identified in the Phase 1 request. The responses were provided in narrative form with the exception of the response from CNS for Spain, which elected to provide its response in the form of presentation slides.

As stated in *Fukushima Daiichi Nuclear Power Plant Accident, Ten Years On: Progress, Lessons, and Challenges* (NEA, 2021), comprehensive reviews have been undertaken across NEA countries to evaluate the safety and robustness of nuclear power plants, including their capacity to withstand major incidents beyond the existing design-basis capabilities for external hazards. Although diverse approaches and methods were used for the reviews, individual NEA member countries reached many similar conclusions regarding the needed safety improvements and enhancements. A shared insight is the need for diversity of equipment, enhancements in the robustness of safety functions, and continuing efforts to improve organisational behaviour. Common activities have included a focus on plant and process improvements to mitigate the potential impact of external hazards. Areas under examination include: i) reassessment of external hazards; ii) improvement of the robustness of the electrical systems; iii) an enhancement of the robustness of the ultimate heat sink (UHS); iv) protection of the reactor containment system, v) protection of spent fuel in spent fuel pools (SFPs); vi) reinforced capability to rapidly provide diverse equipment and assistance from on-site or off-site emergency preparedness facilities; vii) reinforced safety culture, including human and organisational factors in decision making during emergencies; viii) continued safety research; and ix) consideration of events that could affect all the reactors at a single site simultaneously (multi-unit events).

The working group reviewed the responses to the Phase 1 information request and found that the responses from the sample of countries participating in this WGHOFF initiative were consistent with the general characterisation provided by the NEA in its 2021 report. Additionally, the WGHOFF task group made the following observations, based upon the Phase 1 responses, with respect to: (1) the scope of the events addressed by the post-Fukushima actions; (2) the general characteristics of measures that were being taken; and (3) the types of personnel actions that are being used to mitigate extreme external events and severe accidents.

### Scope of events addressed

- all address impact of extreme external events (some including new phenomena);
- many address multiple unit events;
- many update severe accident management guidance;
- some add capabilities/guidance for extensive damage/loss of large areas of the plant.

### Characteristics of response

- all include the addition of new equipment for accident mitigation;
- responses vary with respect to relative emphasis on installed vs portable equipment;
- all result in numerous revised and additional procedures/guidelines for event response;
- all include augmentation of personal protection equipment;
- most include an assessment of staffing adequacy and capability for staff augmentation;
- most include the addition of pre-staged equipment off-site;
- most update/augment emergency response organisations and facilities;
- some include measures to improve management of stress;
- nearly all significant enhancements to response capabilities depend on human action.

### Types of actions

- selecting event mitigation/accident management strategies;
- securing emergency power sources;
- implementing load shedding;
- securing makeup/injection water;
- transporting, connecting, and operating portable equipment;
- cooling and refuelling of portable equipment;
- monitoring/maintaining fuel pool water levels;
- removing debris to establish access/transport pathways;
- maintaining control room habitability;
- providing supplies and accommodations to maintain worker fitness;
- fighting large area fires;
- supplementing response with off-site personnel, equipment and supplies;
- suppressing off-site radioactive release;
- assessing multiple source term release;
- carrying out containment venting;
- limiting dose to personnel accessing irradiated fuel bays.

Given the number and diversity of actions being undertaken in the countries participating in this initiative, a detailed accounting of the specific actions is beyond the scope of this summary report. However, such details are available in the Phase 1 responses provide by each participating country, which may be found in Appendix A.

### Potential HOF implications and challenges

The objective of this effort was to understand the HOF implications and challenges of implementing the post-Fukushima actions. To that end, the task group observed that the Phase 1 responses confirmed that the preponderance of enhancements to mitigation capabilities for extreme external events and severe accidents depend on human actions, rather than installed, passive or automated, engineered safety features. Whereas this approach leverages the flexibility and adaptability of humans, the effectiveness and reliability of these actions is likely to be challenged by stressors that may be new or more intense, in comparison to those experienced under normal operations or even design-basis accident conditions. It is also noted that the human actions required for these new strategies are not limited to simple manual tasks, but in some cases require complex analysis and decision making, cognitive tasks that can be vulnerable to stressors (e.g. time pressure, incomplete/inconsistent information, threat of death or injury) likely to be present during such events.

The challenges presented by extreme event conditions to human performance were the focus of *Human Performance under Extreme Conditions with Respect to a Resilient Organisation* (NEA, 2015). In that report, extreme conditions are characterised as having one or more of the following event attributes:

- unexpected, not covered by training or procedures;
- beyond design basis, loss of safeguards and safety barriers;
- dynamic, rapidly changing, escalating or accumulating;
- insufficient and unreliable information;
- complex and potentially long-term duration;
- challenging to the organisation (on-site and off-site);
- potential adverse health consequences including loss of life.

The effects that such extreme conditions can have on human performance are well documented in the human factors literature. For example, NUREG/CR-5680, *The Impact of Environmental Conditions on Human Performance*, provides a compendium of such information applicable to nuclear power plant workers (NRC, 1994a). Volume 1 of the NUREG is a handbook for use by inspectors to help them assess the potential impact (e.g. decreased dexterity, impaired vision, hearing loss, memory deficiency) of specific environmental conditions on licensee personnel performance. The technical basis is summarised in Volume 2, which includes a comprehensive review of the technical literature. Similarly, NUREG/CR-6127, *The Effects of Stress on Nuclear Power Plant Operational Decision Making and Training Approaches to Reduce Stress Effects*, examined the effects of stress in nuclear power plant settings, with a particular focus on the context of severe accident management (NRC, 1994b). The report notes that the following types of impairments in performance have been identified:

- a narrowing and shift in attentional focus;
- a reduced working memory capacity;
- time pressure effects, in one of these two forms;
- speed-accuracy trade-offs;
- incomplete task processing;
- impaired crew communication patterns.

More recently, Laarni (2019) provided a systematic review of the effects of cognitive heuristics among operations and maintenance personnel in nuclear power plants.

Laarni notes that these heuristics may sometimes foster resilience and adaptability in demanding situations but may also lead to cognitive biases and errors.

The literature on human performance under extreme conditions and stressors, such as the reports described above, can help inform our view of the post-Fukushima actions that have been taken to improve accident mitigation capabilities, including the specific measures that have been implemented to mitigate potential adverse effects on human performance. In this regard, we note that the aforementioned NEA report (NEA, 2015), NUREG/CR-6127 (NRC, 1994b), and Laarni (2019), each address methods for mitigating such adverse effects and thereby improving the performance and resilience of plant personnel under challenging operational conditions.

A final observation is that operating companies in many countries implemented a broad range of measures, instituting changes in facilities, equipment, procedures, training, and organisational structures. Although such multi-faceted approaches are commendable, the large number and complexity of changes at each facility introduces the potential for unintended consequences due to deficiencies in the analysis, specification, or implementation of the changes and unforeseen interactions of these elements. Accordingly, we propose that a systemic human, technology and organisation (HTO) approach to implementing these changes, in which the interactions of humans, technology and organisational factors are considered in an integrated manner, could prove useful in gaining the full benefit of these efforts. The NEA report *Human and Organisational Performance in Nuclear Installations* provides a full discussion of the systemic approach, including a view of nuclear facilities as HTO systems and application case studies of the systemic approach (NEA, 2022).



## Chapter 3. Phase 2 summary

### Issuance of requests for lessons learnt

The Phase 2 requests to operating companies for examples of lessons learnt were issued between May 2019 and February 2020. The date of the issuance varied from country to country, based largely on availability of resources to issue and respond to the request. The request described the objective of the information collection, provided an overview of the three phases of the project, and included instructions and a template (described in the section below) for submitting the lessons learnt. The request also noted the lessons learnt would be compiled on a country basis and that any site-identifying information would be redacted.

### Instructions for submitting lessons learnt

The instructions stated that the lessons sought were those gained while implementing post-Fukushima actions that can contribute to the efficiency and effectiveness of complying with requirements and implementing guidance (i.e. accelerate the learning curve) to enhance mitigation capabilities for extreme external events and severe accidents. The instructions also noted that potential sources of and opportunities for such lessons learnt include:

- Stress tests, assessments, drills, exercises or validation efforts that resulted in identifying ways to improve mitigation capabilities for extreme external events and severe accidents.
- Instances when guidance from the regulatory authority was limited or not applicable, and additional site-specific guidance or alternative guidance/methods were developed to meet the need.
- Instances when initial attempts to meet regulatory requirements did not fully achieve the intended outcome and subsequent changes or exceptions to the accepted method resulted in improved outcomes.
- Any area where the endorsed guidance was used but it was possible to use an innovative approach to compliance or meet the new safety objectives.
- Any modifications to facilities, equipment, programmes, procedures, or training not specifically identified in the regulatory authority's requirements or guidance but implemented to enhance capabilities for response to and mitigation of extreme external events.

To aid operating companies in identifying candidate activities that may have produced lessons learnt, the instructions included example categories. The example categories were the same as those provided to regulatory authorities in Phase 1 and which are summarised in Chapter 2, Table 1 of this report.

The instructions also included a ten-question template that was to be used for summarising and submitting a lesson learnt in a standardised format. The response template is reproduced on the following pages as exhibit 1.

### Exhibit 1

1. Concisely describe the lesson learned noting the challenge and how it was resolved or overcome (i.e. describe a success story). See Note 3 at the end of this form for guidance on the level of detail to provide.

2. List the names of any files that you are submitting with this form to supplement your description of the lesson learned (e.g. photo, diagram, report). If none, please type, "not applicable".

3. Briefly describe the obtained or anticipated benefits of this insight/resolution (e.g. performance, safety improvement, cost reduction).

4. This lesson learned has implications for (you may check both.):

- On-site Response (Mitigating Event)  
 Off-site Response (Protective Actions for Public)

5. This lesson learned has implications for performance in the following plant locations. Check all that apply.

- Main Control Room  
 Remote Shutdown Panel/Facility  
 Other Local Control Station/Field  
 Activities Technical Support Center  
 Emergency Operations Facility  
 Other (Please specify.) \_\_\_\_\_

6. This lesson learned has implications for personnel in the following job categories. Check all that apply.

- Control Room Operators  
 Field Operators  
 Maintenance Technicians  
 Health Physicists/Radiation Protection/Chemistry  
 Other Emergency Response Organization Personnel  
 Security  
 Other (Please specify.) \_\_\_\_\_

7. This lesson learned concerns (check all that apply.):

- Mitigation Strategies  
 Other Procedures and Guidelines  
 Staffing



- Organizational Structures
- Communication
- Decision-making Authorities
- Safety Culture
- Personnel Qualifications
- Training
- Plant Instrumentation/Controls
- Human-System Interfaces
- Communications Equipment
- Work Planning
- Technical Support
- Emergency-response Facilities
- Emergency-response Plans
- Extended Longer-term Response
- Other (Please specify.) \_\_\_\_\_

8. This lesson learned was identified during:

- Initial Analysis/Development of the Action
- Validation
- Training
- Drill/Exercise
- Audit/Self-assessment
- Other (Please specify.) \_\_\_\_\_

9. The events described in this lesson learned occurred in what country and between what months and years?

E.g. France from May 2009 to July 2009

10. Please write the name of the person who completed this Lessons Learned Report and provide the date. Kindly note that the name of the individual/organization contributing the lesson learned will not be made public.

E.g. Jane Doe on 17 May 2019

*Note 3: When providing your description of the lesson learned, please be concise yet provide a level of detail sufficient for a reader to evaluate the potential applicability to their facility and the benefit to be gained by implementing the lesson learned. These details likely include:*

- *the requirement, guidance, or need that was addressed*
- *the action/method taken*
- *the insight gained/results achieved that are the basis for the lesson learned*

*Types of information that you do not need to provide are site-specific details (e.g. equipment/ component identifiers), instead use generic terms. The amount of text necessary to provide these and other relevant details will vary according to the complexity of the circumstance, but generally should not be more than a couple paragraphs. If helpful, you may include supplemental files (e.g. photos, diagrams, reports) with your submission and list these in Section 2 of this form.*

## Lessons learnt summaries and examples

As noted in Table 1, the task group received submissions from seven countries in response to the Phase 2 information request. Collectively, these countries submitted 40 lessons learnt reports. In addition, Japan submitted an integrated summary of actions implemented in Japan. Their summary addresses each of the ten topical areas addressed in Table 2. The information gathered through these submissions is provided in a standardised format in Appendix B of this report. The following subsections provide overviews of the submissions provided by each country. In addition, each section highlights a specific submission in a more detailed discussion.

### Canada

In response to the Phase 2 request for information, the Canada Deuterium Uranium (CANDU) Owners Group (COG) provided eight Fukushima lessons learnt summary sheets. COG is an industry group that represents all owners of CANDU reactors. Of the eight responses, seven relate specifically to the broad recommendation to “enhance emergency response capability”. The responses provided are from Canadian nuclear power plants and Canadian Nuclear Laboratories. The following is a listing of the topics submitted:

1. Emergency Management Centre (EMC).
2. Emergency Mitigating Equipment (EME).
3. Incident Management System (IMS).
4. Public alerting systems.
5. Remote Automated Gamma Monitoring System.
6. Emergency Satellite Communication System (ESCS).
7. Unified RASCAL (Radiological Assessment System for Consequence Analyses) Interface (URI).
8. Web Emergency Operating Center (WebEOC).

To highlight the work done in the Canadian industry, implementation of the remote automated gamma monitoring system will be described in further detail. This illustrates how the actions taken by licensees relate specifically to the recommendations made by the CNSC Fukushima Task Force (CNSC, 2011) and address one of the lessons learnt from the Fukushima event.

#### *Remote automated gamma monitoring:*

In Phase 1, the CNSC reported on the Fukushima Task Force Recommendations (CNSC, 2011). There were four broad categories:

- strengthen reactor defence in depth;
- enhance emergency response capability;
- improve the regulatory framework and processes;
- enhance international co-operation.

Within each of these broad categories, there were a number of recommendations supported by several actions for each, with closure criteria identified. Licensees were requested to respond to the first two, with the second two being actions undertaken by the CNSC in response to the Fukushima accident.

The Fukushima event highlighted the need to improve emergency response capabilities. This included, but was not limited to, upgraded emergency response facilities, sharing of data between organisations, improved communications capabilities, and public alerting systems.

With respect to the implementation of Remote Automated Gamma Monitoring (Appendix B, Lesson Learnt: CA-05 Remote Automated Gamma Monitoring System) the requirements can be traced to CNSC's Phase 1 submission for Canada (Appendix A, Canada).

- Recommendation 5 – Update Emergency Facilities and Equipment

Action A.5.3 – Licensees should install automated real-time station boundary radiation monitoring systems with backup power sources and communication systems. This action has Human and Organizational Performance (HOP) closure criteria expectations.

- Action Item A.5.3.1 – Develop a plan/schedule for completion of installation.

HOP Closure Criteria for Action A.5.3 – Provisions made for identification and consideration of any relevant elements of HF involved in development and deployment of modelling tool.

Prior to 2012, manual off-site collection and analysis of remote radiological data was necessary. In practical terms, it took about two hours for the station to mobilise its off-site survey teams to start the collection and transfer of data to the on-site and off-site stakeholders. This was a cumbersome process requiring several individuals (six at one station) travelling to the various monitoring locations to take gamma readings. Weather, time of day and off-site conditions could all impact the ability to successfully carry out these activities. This practice also increased the potential for worker exposure during an event and data was not available real time to agencies such as the Province of Ontario, and the Office of the Fire Marshal and Emergency Management, which makes protective action decisions for the public.

In order to address Action Item A.5.3, licensees implemented enhancements to the remote monitoring systems at the stations. The improved monitoring system collects data via permanently installed automated gamma monitors along the site boundary as well as locations within the primary zone (up to 10 km) to monitor any potential releases. The data is collected remotely and sent wirelessly to a centralised system which interfaces with the current station information local area network (LAN) systems.

Primary data transmission is via the cellular network, with backup satellite capability. Data storage and external data access is provided through a remote off-site third-party data storage network with appropriate cloud security, backup power, and storage facilities.

The remote automated gamma monitoring system provides real-time data (24/7) which is essential to quickly identify the existence of radiological hazards during a major event. These data play a critical role in supporting the decision-making process related to employee and public safety. Use of the system enables real-time modelling of plume progression which is shared with the emergency response organisations called into play during a nuclear event including local, provincial, federal and regulatory authorities.

Implementation of the automated gamma monitoring system will reduce personnel exposure, reduce the likelihood of human error, and improve the availability and accessibility of data for use by stakeholders.

Installation of the remote automated gamma monitoring systems at the utilities has improved emergency response capabilities, one of the recommendations from the CNSC's Fukushima Task Force. This system will offer added protection to licensee staff and the public in the event of an emergency. Human factors were considered in the design of the remote automated gamma monitoring system and the effectiveness of the system has been validated through various site drills and exercises.

During a field walk down of the remote automated gamma monitoring stations at one of the nuclear power plant facilities, it was noted that the units measuring gamma fields were different on some of the stations. This inconsistency had the potential to trigger unnecessary protective actions. There was also the potential to assume radiological conditions were not as bad and therefore necessary protective action decisions would not be made. Fortunately, when the discrepancy was identified, the operator took the necessary steps to ensure that all units measured the gamma fields in the same stations. It was also confirmed that the software for the system also used consistent units of measurement. Validation thus plays an important role in ensuring the adequacy of any new measure taken to enhance emergency response capability.

Figure 2. **Remote Automated Gamma Monitoring Station**

Source: Canadian Nuclear Safety Commission.

### **Czech Republic**

In response to the Phase 2 request for information, the CEZ Company (represented by the Accident Management Department of Czech nuclear power plants) provided five lessons learnt summary sheets. CEZ is an industry group which operates both Czech nuclear power plants. The following is a list of the topics submitted:

1. Provision of Mobile Diesel Generators (MDG).
2. Enhancement of communication equipment.
3. New backup (diverse) and alternate (mobile) emergency response centre.
4. Improved procedures for diverse and mobile (DAM) equipment and emergency operating procedures (EOPs).
5. New Extensive Damage Mitigation Guidelines (EDMG).

#### *Procedures for diverse and mobile equipment:*

One of the measures implemented at Czech nuclear power plants after the Fukushima Nuclear Power Plant accident was the installation of DAM equipment. DAM equipment is intended to ensure basic safety functions, especially for long-term blackout events, also called extended loss of AC power (ELAP) events, complete loss of ultimate heat sink (LUHS) events, combination of ELAP and LUHS, as well as multi-unit events. The new DAM equipment dramatically improved the ability of the plants to respond to all events leading to ELAP and LUHS caused by external hazards or other initiators.

Using the new DAM equipment required development of new specific procedures to extend the applicability of emergency procedures considering all states resulting from design-basis accidents as well as design extension conditions. The new DAM procedures are:

1. DAM-1: Primary system injection.
2. DAM-3: Injection of feedwater into steam generator.
3. DAM-5: Initial assessment of nuclear power plant status and dislocation of mobile equipment.
4. DAM-6: Emergency makeup of demineralised water tanks.
5. DAM-7: Loss of key parameters measurement.
6. DAM-8: Boron makeup into the reactor coolant system.

7. DAM-10: Hydroaccumulators isolation.
8. DAM-11: Spent fuel pool makeup.
9. DAM-12: Containment depressurisation.
10. DAM-13: Switch from mobile equipment to design equipment.
11. DAM-14: Low pressure primary system injection.

The corresponding links to specific DAM procedures were subsequently incorporated into the original emergency operating procedures (EOPs/ECA-0.0, Blackout), Shutdown procedures (SD/SD-0, Shutdown blackout) and Severe Accident Management Guidelines (SAMG) to provide a comprehensive and interconnected structure of the emergency management documentation. Upgrading documentation to cover the events in the scope of design extension conditions lead to significant safety improvements in the area of accident management programme implementation at Czech nuclear power plants.

An analysis of the recovery of power supply to required electrical loads using MDGs (see Figure 4) was performed by UJV (Czech Nuclear Power Engineering Company) using a probabilistic safety assessment (PSA) model (UJV REZ, 2018). Two variants were considered in the analysis: (1) power supply recovery performed for one unit only and (2) power supply recovery performed sequentially for all four units (with available time being ten hours in total, see Figure 3). Four external hazards were considered in the analysis: (1) earthquake, (2) high winds, (3) extreme snowfall, and (4) extremely low temperatures. The expected time windows of specific manipulations were examined (i.e. measured during a regular drill) and discussed with plant personnel. Task allocation, way of communication (i.e. methods and protocols), and sequence of required actions were discussed with the relevant local operators. The following personnel were required to take part in the scenario:

- control room operators (three per unit);
- shift electrician (one per nuclear power plant);
- inspection electrician (one per nuclear power plant);
- operational electrician (four per nuclear power plant);
- fire brigade;
- DELTA team (special emergency team dedicated to local actions).

UJV developed the following timeline to illustrate the sequence of the expected failures and required actions:

Figure 3. Sequence of expected failures and required actions in SBO scenario

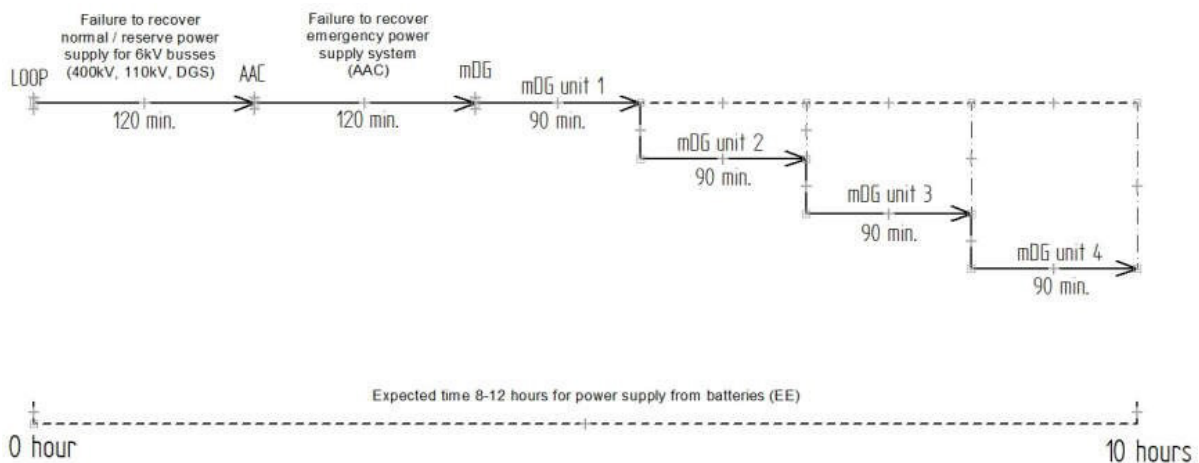

Notes: Alternative alternating current system (AAC), diesel generator system (DGS), external events (EE), loss of off-site power (LOOP), mobile diesel generator (mDG).

Source: ÚJV Řež, a.s.

The failure probability of power supply recovery using the MDG was calculated for “normal” conditions as well as for cases caused by external events. Based on this analysis, two recommendations were formulated:

### Staffing

In the case of a multi-unit event, the inspection electrician can be expected to have some problems performing the required actions in time, since there is only one inspection electrician per nuclear power plant. UJV recommended an increase in the number of inspection electricians or to share some of the responsibilities of this position with shift electricians, of which there are four per nuclear power plant.

### Procedures

It was found that some of the required actions (e.g. transport of a heavy spool with cables from the ground floor to the second floor) may require an increased number of personnel. It would be beneficial to state such information directly in DAM procedures to avoid any delays during emergencies.

Figure 4. **Mobile Diesel Generator 4 x 352 kW (one per unit)**



Source: ÚJV Řež, a.s.

### Japan

The FEPC facilitates the development of collective utility policies and strategies related to the electricity business in Japan. In response to the Phase 2 request for information, the FEPC provided a detailed response describing actions taken or to be taken for each of the 10 HOF topical areas identified in Table 2. The following is a summary of the information FEPC provided. The complete response is available in Appendix B.

Prior to the Fukushima Daiichi accident, nuclear power plants were lacking emergency response preparedness for a severe accident due to external events that exceed design-basis events. As a result, it was made clear from the accident that the chain of command was confused, materials and equipment ran short, and quick and firm information sharing and communication were insufficient. Based on these lessons learnt, licensees have been making efforts to strengthen emergency response and to enhance the response capability.

The Fukushima Daiichi accident has made it clear that a phased approach may be necessary for an effective accident response. Specifically, as shown in Figure 5, resources can be used most

effectively if the time since the occurrence of the accident is separated into three phases and accident response is implemented appropriately in each phase.

- Phase 1 starts immediately after an accident. Operators and ERO shift personnel that are stationed at the plant are expected to engage permanent facilities and mobile equipment to respond to the accident. This is a basic requirement for safety facilities.
- Phase 2 starts when additional personnel called on after the accident have gathered at the plant and an additional accident response, such as the use of mobile equipment located on station premises, can be initiated.
- Phase 3 starts at least seven days from the day of the accident. In this phase, support from off-site personnel, equipment and materials can be expected.

Based on this phased approach, safety improvement measures are being discussed not only for hardware issues but also for personnel/organisational issues such as ERO staffing and manuals.

Figure 5. **Conceptual diagram of a phased approach in accident response**

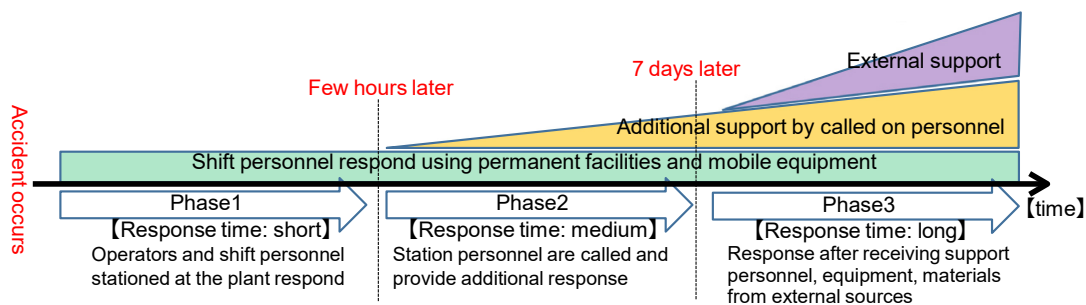

The three basic safety functions for power generating nuclear reactor facilities are “stop”, “cool” and “contain”.

Severe accident response measures have been developed to prevent the core from significant damage due to any cause, even if the facilities to deal with design-basis accidents have lost the ability to eliminate the risk posed by unforeseen events. These facilities have been made independent from the design-basis accident response facilities as much as possible.

Examples of measures are as follows:

- Water injection and heat removal functions (enhance 3<sup>rd</sup> layer of defence in depth, See Figure 6):
  - Enhance high pressure injection function: high pressure alternate cooling system.
  - Enhance depressurisation: backup actuation mechanisms for SRVs.
  - Additional water source: reservoir.
- Protection of containment vessel and prevention of uncontrolled release of radioactive materials (enhance 4<sup>th</sup> layer of defence in depth):
  - Protection of containment by preventing over-pressure/temperature: top head flange cooling, increased durability of seal in severe accident environment.
  - Mitigation of radioactive material release: filtered vent.
  - Prevention of hydrogen explosion: passive autocatalytic recombiner.
- Power supply functions:
  - Measures for quick power supply:
    - Gas-turbine generators and power supply cars on higher ground.
    - Emergency switchgears and installed electrical cable.
  - Reliability enhancement of DC power:
    - Additional DC power on the top floor of the reactor building.

Figure 6. Safety measures to enhance third layer of defence in depth for ABWR

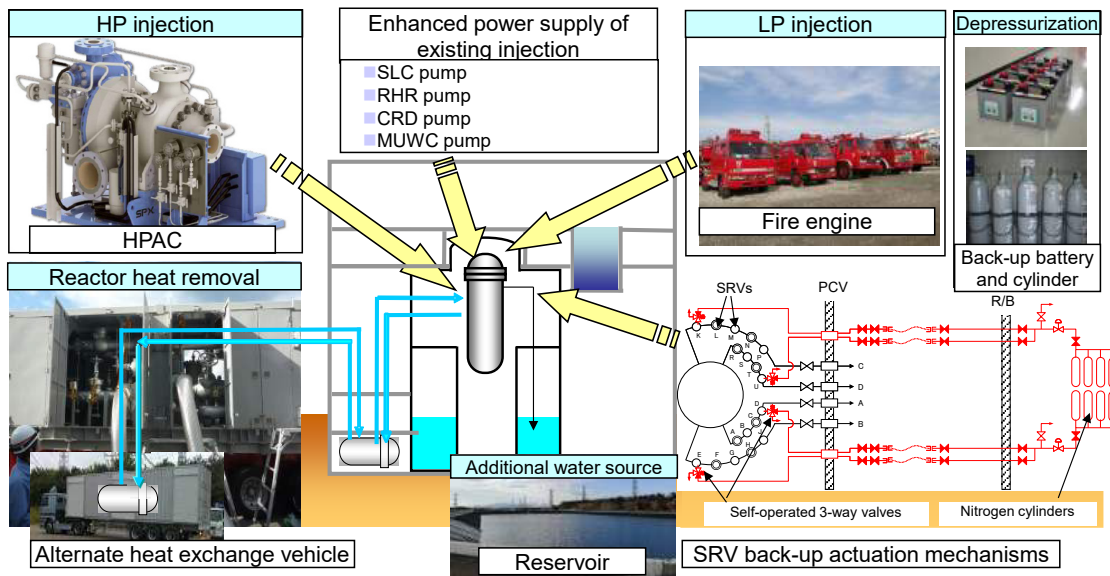

Notes: Control rod drive (CRD), high pressure (HP), high pressure alternate cooling (pump) (HPAC), residual heat removal (RHR), standby liquid control (SLC), safety relief valve (SRV), protection of containment vessel and prevention of uncontrolled release (enhance fourth layer of defence in depth).

Other examples of countermeasures based on the Fukushima Daiichi Nuclear Power Plant accident are as follows:

- Operation of emergency organisation: An incident command system (ICS)<sup>1</sup> was introduced to clarify the chain of command.
- The development of the guidelines and procedures: EROG and EHP were developed to improve ERO's capability to respond to a severe accident like the Fukushima Daiichi accident.
- Activities relevant to improvements in personnel capability and assignment:
  - Training for radiation management personnel: At the Fukushima Daiichi Nuclear Power Plant, since the number of skilled radiation management workers was very small compared to the total number of staff working at the plant, support from other sites was necessary.
  - Training and Certifications: Having few workers licensed to use large vehicles inhibited emergency work such as removing the debris generated by the tsunami and the hydrogen explosions. The relevant recovery work was delayed and transportation between J-village and Fukushima Daiichi was restricted at the beginning of the recovery work.
  - Assignment of personnel: Since restoration work after the accident was expected to be a long-term effort, a system of shifts was necessary. However, to make this shifting regime function, it was necessary to assign work appropriately according to the personnel's abilities.
- Enhancing internal communication: It is necessary to communicate and share information with interested parties, even under difficult situations, such as loss of power. This enhancement aims to make sure necessary information is shared, even in case of

1. An equivalent standardised emergency organisation management system exists in the United States (fire department, police, military, etc.) with regard to on-site command applied to disaster/crime sites.



AC/DC loss. For that purpose, a radio communication facility, satellite phone and transceiver were installed.

- Enhancement of external communication (see Figure 7):
  - Enhancement of liaison function with external organisations.
  - Upgrade of communication tools: video conference system, simultaneous fax system, and mobile communication tools (dedicated line or satellite circuit).
  - Risk communicators to ensure better external communication.

Figure 7. **Example of improvement of external communication**



Notes: Off-site centre (OFC), personal computer (PC), personal handy phone system (PHS).

### France

In response to the NEA WGHOF Phase 2 information request, the IRSN provided a lesson learnt submission describing insights gained from exercises evaluating the minimum staffing of the operation team (a summary of that response is provided in Appendix B, France). The following is background to that lesson learnt.

#### Regulatory requests

In Europe, the scope of the “stress tests” carried out as part of the Fukushima lessons was harmonised by European regulators through the ENSREG association (see. Phase 1 France report).

The French request for a “stress test”, called ECS (Evaluation complémentaire de sûreté), was issued within a few weeks by the Prime Minister to the French nuclear safety authority (ASN) and then to the nuclear operators. The regulator (ASN) set three key objectives:

- to avoid significant releases into the environment and long-lasting contamination;
- to ensure robustness against more severe hazards than the design-basis events (commonly referred to as design extension), prevent fuel melt, mitigate severe accident; and to cope with long-lasting and multi-unit accidents induced by extreme hazards;
- to perform emergency management duties in extreme contexts.

The focus of the ECS was on severe hazards (earthquake, flooding) and the ASN request was more specifically also on scenarios of loss of electricity (LoE) and cooling (LoC). The request dealt with measures to prevent a core melt and mitigate severe accidents (with support of subcontractors). Several requirements were prescribed by the ASN (see Appendix A, France for additional details).

### *Actions taken by the French nuclear power plant licensee, Electricité de France*

The licensee defined the concept of “hardened safety core”. The strategy is to protect and strengthen critical structures, systems and components to prevent and mitigate severe accidents initiated by beyond-design-basis accidents (BDBA) induced by natural hazards. The operational objective is to prevent core melt despite loss of cooling and/or electricity. The goal is to cover all reactor states, spent fuel pools, multiple simultaneous reactor accidents, and large volumes of contaminated water. It led to the extension of the scope of severe accident management (e.g. residual heat reduction without venting and with water injected). The main control room was provided with more robust and redundant instrumentation (e.g. water temperature and level, radiation in containment building and outside, time to boiling point, hydrogen, earthquake, core melt), powered by new batteries and backup diesel generators. The operator built new emergency control rooms within new buildings resistant to extreme situations and established redundant and robust telecommunication systems. New organisational means were set up with 300 people on duty in four locations in France, ready to implement mobile equipment (e.g. to supply water, electricity, air, fuel) within 24 hours. The minimum staffing for the operation team was also revised.

At the public level, the national nuclear emergency plan was updated. The local emergency plans are expected to be updated and the radius to consider inhabitants’ exposure and involvement was raised from 10 to 20 km. Additional detail concerning the ASN regulatory requests and the actions taken by Electricité de France can be found in Appendix A, France.

### *Implementation of minimum staffing in operations team*

The Fukushima accident showed the need to guarantee the autonomy of nuclear power plant staff, especially after extreme natural hazards when the plant can be isolated (e.g. Blayais in 1999).

The post-Fukushima regulatory request (ECS35-1) was to ensure that all actions required are feasible even in extreme contexts and can be performed by qualified staff.

The nuclear operator developed a method focusing on operations (main control room [MCR] and field actors) interfacing with national crisis teams, using simulator calculations to define the timing and deadlines to perform critical actions to prevent loss of control. The goal was to establish the general time and staffing levels needed with sufficient margin to control the situation. The nuclear operator conducted several exercises in 2014, 2015, 2016 on one or two MCR simulators on loss of coolant (LoC) and loss of electricity (LoE) scenarios that were controlled by the operations team. The nuclear operator assumed that the operations team might have to perform them all without the support of local emergency teams for 24 hours. It led to the addition of one supervisor for the two operators in the MCR by 2020; the chief and deputy of the operation teams are in charge of key decisions, safety control, and external interfaces.

To reduce the operations staff workload, some operator actions should be prioritised by modifying dedicated procedures but the diversity of situations due to unexpected scenarios limits this possibility. This potentially leaves a significant workload for the operations team in real time. The operations team workload has been adapted by changing roles and responsibilities as proposed by the operator. However, the exercises (mentioned above) highlighted the challenge of accumulating functions onto the lead members of the operations team (chief, deputy and supervisor).

The exercises also showed the multitude of influence factors on human actions in the field (e.g. darkness) and the difficulty to translate them into quantitative analyses of time and staffing margins. In this domain, the implementation of post-Fukushima actions revealed that there is a lack of fundamental scientific and evidence-based data on the quantitative impact of influence factors on human actions. Conducting risk analyses in the case of extreme events may further show that design measures could be necessary to protect paths and workplaces to ensure that necessary actions can be performed.

## Korea

In response to the Phase 2 request for information, the Korea Hydro and Nuclear Power Co. Ltd. (KHNP) provided 15 lessons learnt summary sheets. The nuclear power plant operator, KHNP, is the only licensee in Korea. The following is a listing of the different topics submitted:

1. Conducting stress tests in Korea's nuclear power plants.
2. Securing additional equipment in preparation for prolonged emergency.
3. Reinforcing radiation emergency exercises.
4. Devising a means for securing necessary information in case of a prolonged loss of electrical power.
5. Amending the radiological emergency plan to include such events as the simultaneous declaring of an emergency at multiple units.
6. Improving the seismic capacity of the seismic alarm in the main control room.
7. Reinforcing education and training on severe accidents.
8. Revising the Severe Accident Management Guidelines (SAMG) to enhance effectiveness.
9. Developing low-power shutdown SAMG.
10. Improving the emergency response facilities.
11. Assessing the adequacy of operating manpower.
12. Developing accident coping strategies.
13. Strengthening the accident management programme.
14. Ensuring Multi-barrier Accident Coping Strategy (MACST) equipment availability.
15. Setting up a MACST team.

### MACST (*Multi-barrier Accident Coping Strategy*)

Since the Fukushima accident occurred, the public in Korea has become increasingly concerned about the safety of nuclear power plants in conditions of extreme natural hazards such as earthquakes or tsunamis exceeding the design basis. As described in the Korea response to the Phase 1 information request (see Appendix A, Korea, Section 3), as part of its response to the Fukushima Daiichi accident, the regulatory body established criteria for accident management. To address these requirements, KHNP established MACST, through which emergency response up to 72 hours after the onset of an extreme natural hazard accident is made using on-site equipment. It has assessed that 72 hours is sufficient to secure an access route for off-site personnel and equipment. In order to cope with extreme external events, three phases of coping strategies are developed with MACST equipment. Figure 8 shows the coping strategies, that is MACST, to cool the reactor core.

- Phase 1: Initially cope with equipment in the plant, such as tanks, piping, batteries, and pumps, within eight hours of the accident.
- Phase 2: Cope with equipment on site, such as mobile generators, and mobile pumps, between 8 and approximately 72 hours after accident initiation.
- Phase 3: Cope with all available equipment, including equipment delivered from off-site, after 72 hours from accident initiation.

For the coping strategies, MACST operating guides (MOGs) are prepared. Table 3, Figure 8 and Figure 9 show the purpose of each MOG and the relation between procedures used in the emergency situations. MACST equipment for Phase 1 are stored inside each unit to use as soon as possible. Except the pre-staged equipment, other mobile equipment for Phase 2 and Phase 3 are stored in the seismic designed integrated storage building which is constructed for each site. Besides the MACST equipment for essential safety functions, subsidiary equipment such as multipurpose communication units, emergency lighting, tractors, and wheel loaders is also stored in the integrated storage building.

Table 3. List of MACST procedures

MOG No.	Purpose
1	Long-term reactor coolant system inventory control
2	Alternative auxiliary feed water supply
3	Alternative low pressure injection
4	Battery load shedding after extended loss of all AC power
5	Site survey and MACST equipment deployment
6	Condensate storage tank makeup
7	Electrical loss of essential instrument
8	Alternative borated water injection
9	Temperature control at low decay heat
10	Safety injection tank isolation
11	Alternative spent fuel pool makeup and cooling
12	Alternative containment building cooling
13	MACST equipment termination (turnover)
14	Reactor coolant system makeup during shutdown

Source: Korea Hydro & Nuclear Power Company.

Figure 8. MACST core cooling strategies

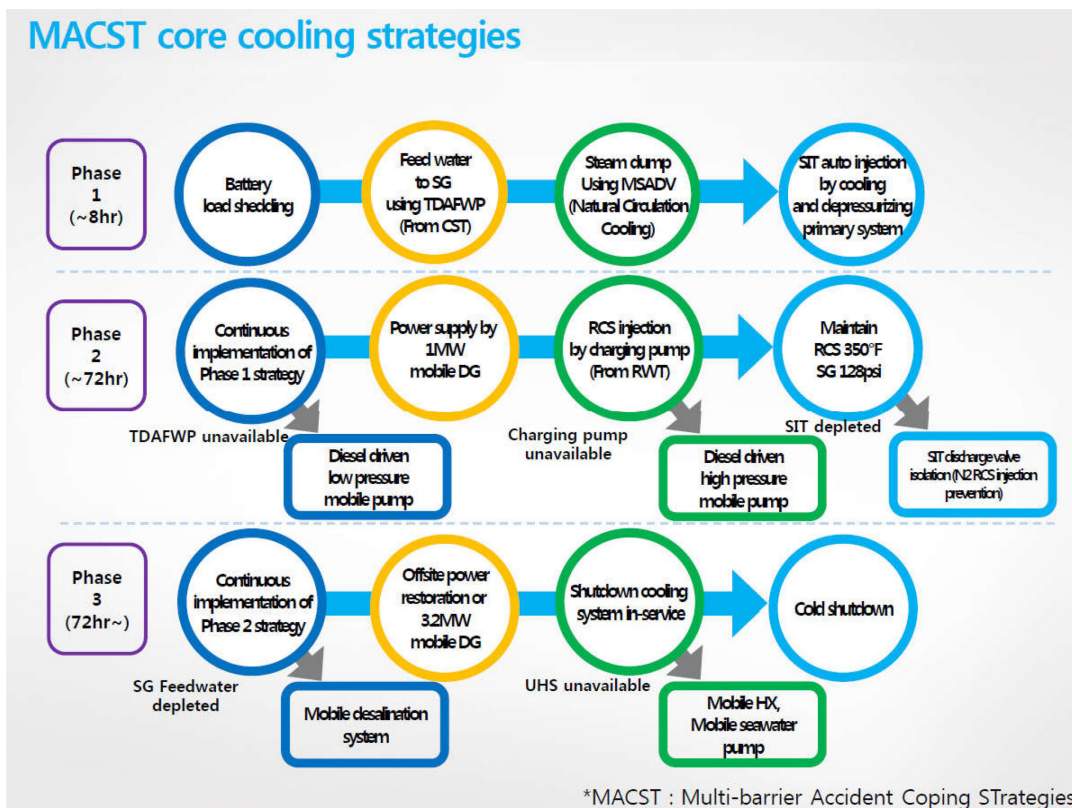

Notes: Steam generator (SG), turbine driven auxiliary feed water pump (TDAFWP), condensate storage tank (CST), main steam atmosphere dump valve (MSADV), safety injection tank (SIT), diesel generator (DG), reactor coolant system (RCS), refuelling water tank (RWT), ultimate heat sink (UHS), heat exchanger (HX).

Source Korea Hydro & Nuclear Power Company.

Figure 9. Relation between procedures

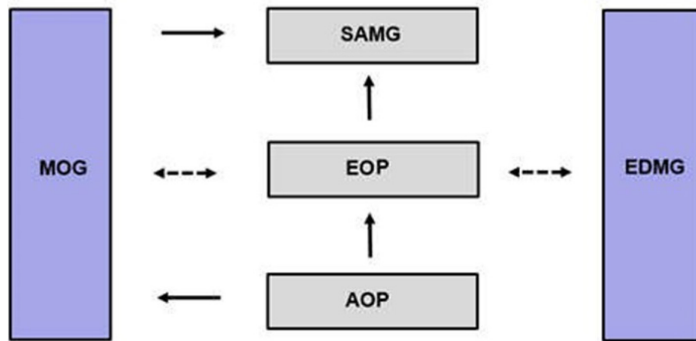

Notes: MACST operating guideline (MOG), Severe Accident Management Guideline (SAMG), abnormal operating procedure (AOP), emergency operating procedure (EOP), Extensive Damage Mitigation Guideline (EDMG).

Source Korea Hydro & Nuclear Power Company.

*Example of MACST equipment (3.2 MW mobile generator):*

The mobile generator has a capacity of 3.2 MW to supply electrical power for the safety-related A or B bus during an extended loss of AC power (ELAP) accident. It has enough capacity for all essential equipment including the cooling pumps, motor operated valves, HVAC, etc. The objective is to cool down the plant to the cold shutdown status after 72 hours since the accident occurred. However, like the pre-staged 500 kW generator, the pre-staged and pre-wired electrical lines of a 3.2 MW generator can reduce the time to establish an alternate power source drastically and remove the uncertainty of transportation. A few (two or three operators) can start the generator and supply the electrical power instead of 18 workers. Two 3.2 MW mobile generators are placed at each site. They are pre-staged with pre-installed cables even though they are still mobile. Unlike the pre-staged 500 kW generator, the 3.2 MW mobile generators are staged on a remote area more than 100 metres from the unit and they use long pre-installed cables. The remote area has dedicated fuel tanks with a protection dike. The 3.2 MW mobile generators are commercial grade and non-seismic but the pre-staged foundation, fuel tanks, and dike are seismically designed.

Figure 10. 3.2 MW mobile diesel generator (Korea)



Source Korea Hydro & Nuclear Power Company.

## Spain

In response to the Phase 2 request for information, the Spanish Nuclear Energy Committee (Comité de Energía Nuclear, CEN) provided nine lessons learnt summary sheets. The CEN represents both the owner utilities and the licensees of the Spanish nuclear power plants and operates under the umbrella of the Spanish Nuclear Industry Forum (Foro de la Industria Nuclear Española, Foro Nuclear). The responses provided are from Spanish nuclear power plants. The following is a listing of the topics submitted:

1. Verification and validation in emergency situations.
2. Communication during emergency situations.
3. Magnetic help guides for portable equipment.
4. Visual aids for identifying emergency equipment.
5. Training for emergency equipment transport.
6. Communication system improvements.
7. Stress management guide and posters.
8. Leadership during emergency situations.
9. Command and control during emergencies guide.

### SP-01 — *Verification and validation in emergency situations*

These lessons learnt come from the validation of the filtered containment venting system (FCVS), which was installed in nuclear power plant A after the Fukushima Daiichi Nuclear Power Plant accident (as mentioned on slides 47 and 49 of CSN's Phase 1 submission [see Appendix A, Spain], FCVS were requested of the Spanish nuclear power plants):

- Principal lesson learnt: personnel need training to be prepared for these kinds of situations.
- Validations must be done while taking into account the most adverse scenarios.
- Even when procedures cannot take into account every possible situation, human performance specialists need to go further and raise those situations to evaluate responses from plant personnel.
- Difficult personal situations (happening outside the plant) for operators in the field were simulated to analyse their responses (e.g. uncertainty about relatives because of external events affecting the area).
- Management of concurrent relevant mitigation strategies, taking place in the same unit or even in different units of the nuclear power plant, must be considered (e.g. effects of venting in one unit on the mitigation strategies of the other).
- Time available and execution time are no longer the “only” factors to be considered in validations. Other relevant factors include radiation levels, oxygen bottle duration, and high temperatures.
- Validation of the co-ordination between the technical support centre (located in the plant) and the licensee headquarters (outside emergency centre located in Madrid) was conducted as considered relevant.
- Video recording of some parts of the validation exercises was useful.
- A review of the guidance for verification and validation to include lessons learnt has been completed.

Figure 11. **Validation of the filtered containment venting system (1)**



Source CSN.

Figure 12. **Validation of the filtered containment venting system (2)**



#### *Considerations from the regulatory point of view of CSN*

Based on the validation exercises performed by all the Spanish nuclear power plants, from CSN's regulatory point of view, some common additional lessons have already been learnt (or are expected to be considered) by the nuclear power plants:

- Integrated validations must be conducted to be fully effective. They should include, at the same time, different groups of personnel (e.g. licensed operators, auxiliary operators, maintenance staff, fire brigade, radiological protection personnel), different locations (e.g. control room simulator, local sites at the plant, technical support centre, licensee emergency outside centre) and the whole sequences of tasks to be conducted in a co-ordinated way.
- A common and single HOF validation guide should be available at the nuclear power plant. It should be developed by experts according to the state of the art, and it must be used by any of the organisational units of the nuclear power plant (e.g. operation, nuclear safety and regulatory affairs, PSA, engineering, training, maintenance) validating and licensing designs that require human actions.
- This common HOF validation guide should be used as a reference when developing the specific procedures for validating any human action (each validation case might warrant different methods and acceptance criteria). This is applicable to any human actions, independently of its origin (e.g. design modifications, procedures changes, modifications of the FSAR), or its categories (e.g. risk important human actions, local actions).
- Video recording of the validation exercises (an essential tool used by many professional teams to assess and improve individual and team actions and performance: e.g. in sports, high risk activities and industries) becomes necessary to improve validations related to human actions.
- The development, in advance, of clear and detailed validation acceptance criteria is a must.
- It is crucial to consider real operating experiences, and to make use of state-of-the-art validation methodologies and reports, in order to design high quality validation exercises.

## United States

In May 2019, the task group issued an invitation for US nuclear power operating companies to submit post-Fukushima actions lessons learnt. Although no US nuclear power operating company submitted lessons learnt in response to this invitation, the NRC provided lessons learnt submissions on the following topics:

- Development and application of human reliability analysis methods for use of diverse and flexible coping strategies (FLEX) strategies and equipment.
- FLEX diesel generator experience.

These lessons learnt were gleaned from efforts that the NRC Office of Nuclear Regulatory Research has undertaken to examine the application of human reliability analysis methods to the use of FLEX equipment and from the NRC programme for analysis of operating experience. The lesson learnt from FLEX Diesel Generator Experience is described here as an example of the insights gained from the US post-Fukushima action implementation experience.

### *FLEX diesel generator experience*

As described in the US Phase 1 submission (see Appendix A, United States), following the accident at Fukushima, the NRC assembled the Near-Term Task Force (NTTF) to provide recommendations for agency action (NRC, 2011). NTTF Recommendation 4 was to strengthen station blackout mitigation capability for design-basis and beyond-design-basis external events. To address this recommendation, the NRC issued the Mitigation Strategies Order on 12 March 2012 and, in 2019, made final the requirements in Title 10 of the Code of Federal Regulations, Part 155, Mitigation of beyond-design-basis events. In response to these requirements, NRC licensees use FLEX equipment at nuclear power plants to implement long-term core cooling, spent fuel cooling, and containment integrity in beyond-design-basis event scenarios.

On 26 September 2019 and again on 1 April 2020, the licensee for the River Bend nuclear power station conducted periodic testing of their FLEX diesel generators. In both instances, multiple FLEX diesel generators failed to operate. On 11 July 2019, the licensee for Clinton Power Station (Clinton) discovered that the electrical phase rotation of the “A” FLEX diesel generator was opposite to that of the load centre for its in-plant loads. If the facility had used the “A” FLEX diesel generator to power any in-plant equipment, it would have caused phase-dependent loads to rotate backwards, potentially damaging in-plant safety-related equipment.

On 15 September 2020, the US Nuclear Regulatory Commission issued “Information Notice 2020-02, FLEX Diesel Generator Operational Challenges” (NRC, 2020). The information notice informed addressees of these recent operational challenges involving FLEX diesel generators and described the deficiencies in licensee design, testing, and maintenance practices that contributed to the failures. These deficiencies included failure to provide adequate oversight of vendor provided maintenance and failure to test under the loading conditions that would actually be present during a beyond-design-basis external event.

## Insights from Phase 2

The WGHOFF task group reviewed the characteristics of the lessons learnt to understand the commonalities and diversity of the submissions. As described in Chapter 3 and shown in Exhibit 1, respondents to the Phase 2 information request submitted responses using a ten-question template. These questions included several that could be answered by checking the appropriate box or boxes, as applicable. Specifically, questions 4-7 asked the respondent to characterise the applicability of the lesson learnt with respect to on-site or off-site actions (question 4), plant location (question 5), job category (question 6), and HOF topic (question 7). Examining the responses to these questions, the task group found that the sample of 40 lessons learnt had the following general characteristics:

- The vast majority (38) were applicable to on-site activities, though a substantial minority (14) were also applicable to off-site activities. Only two were characterised by the submitters as only applicable to off-site response.



- The lessons learnt were most frequently identified as applicable to the emergency operations facility (29), though the main control room (21), technical support centre (23), and other control locations (20) were also identified frequently as work locations to which the lessons learnt applied.
- Consistent with the results for applicability to plant location, the lessons learnt were frequently characterised as applicable to the personnel of emergency operations facilities and/or technical support centres (23) and other emergency response organisation personnel (30). The lessons learnt were also frequently characterised as applicable to main control room operators (26) and field operators (21), with fewer being seen as applicable to maintenance (11), security (8) or health physics/radiation protection/chemistry (6).
- The HOF topics most frequently identified as the subject matter that the lesson learnt concerned were: mitigation strategies (15), other procedures and guidelines (12), communication (12), emergency response facilities (15), emergency response plans (15), and training (12).

Figure 13. **Applicability of lesson learnt to on-site and off-site activities**

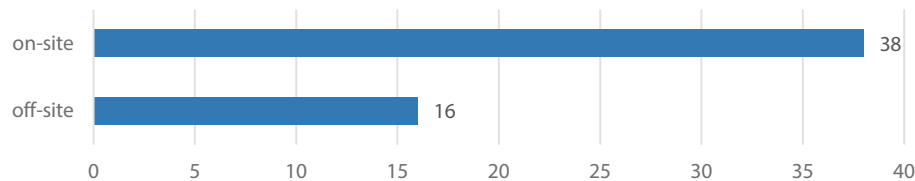

Figure 14. **Applicability of lesson learnt to work location**

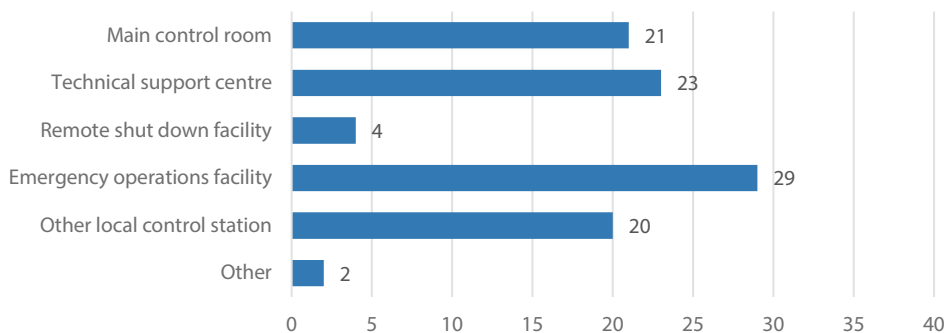
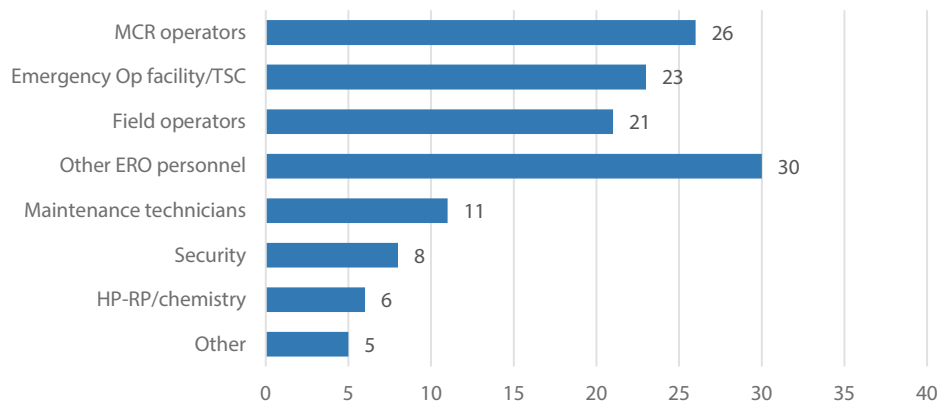
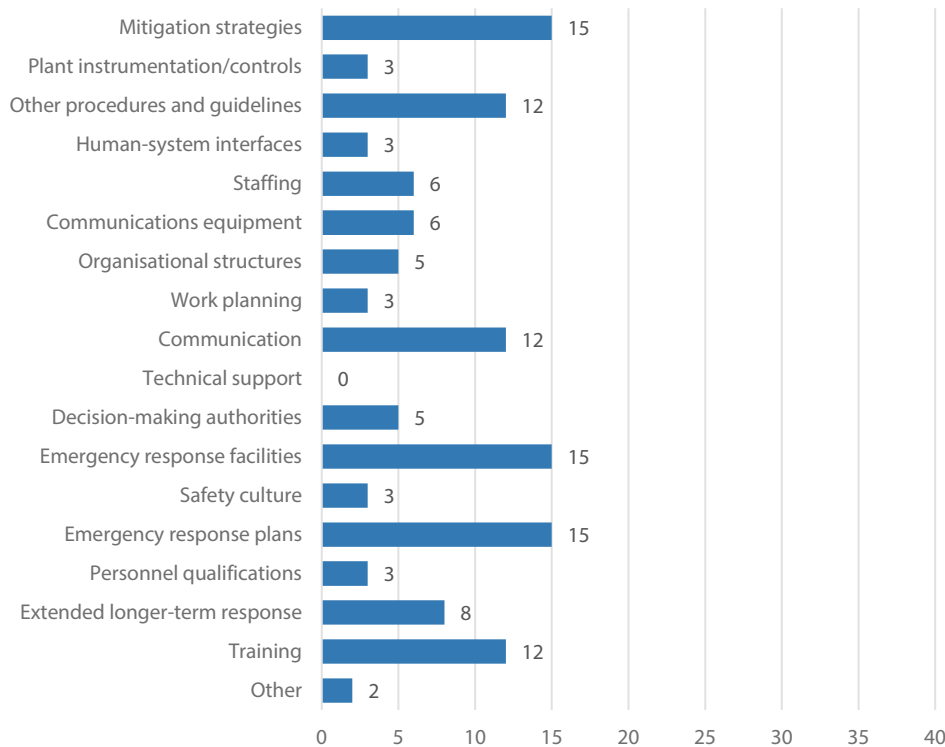

Figure 15. **Applicability of lesson learnt to job categories**



**Figure 16. Applicability of lesson learnt to human and organisational factors topical areas**



The task group notes that given the small sample size of lessons learnt and that respondents selected the lessons learnt to submit (i.e. the sample is small and non-random) the reader should not infer that the sample is representative of the population of HOF lessons learnt through implementation of post-Fukushima actions.

The task group also looked at how the lessons learnt were identified. The majority were characterised by the respondent as being identified during initial analysis/development of the action (13) or during audits/self-assessments (21). Only a small number were identified through drills/exercises (2) or validation (2) and none were characterised as the result of training. The task group believes that the relatively small number of lessons learnt being attributed to drills/exercise and training, relative to initial analysis/development and audits/self-assessments, is likely due to both the initial efforts being effective in identifying implementation issues and also the limited opportunity to date for subsequent drills/exercises.

In addition to examining the characteristics of the Phase 2 submissions using the check box responses as described above, the task group examined the content of the narrative responses (i.e. the text description of the lessons learnt). One general observation concerning the Phase 2 submissions is that the responses to the Phase 2 request often describe only the post-Fukushima action that was implemented and do not include implementation lessons learnt. Although this information is quite useful, the objective of the Phase 2 request was to elicit lessons learnt during the implementation phase of actions taken in response to the accident at Fukushima. The ultimate goal of this WGHOF initiative is to be able to provide insights that can be used by others implementing similar actions. The rationale for the focus on implementation lessons learnt was that the task group assumed that decisions concerning what actions were to be taken had already largely been made and therefore HOF insights regarding how to best implement these actions would be the information of greatest current and future relevance. However, the task group found that most of the submissions provided in response to the Phase 2 request focused on describing the actions that were taken and included few HOF implementation insights derived from overcoming initially unforeseen or inadequately addressed HOF challenges.

There may be multiple reasons why the content of the Phase 2 submissions frequently differed from the intended focus.

- The information request may have been misunderstood to be a variant of the same questions that have been a nuclear industry focus for several years since the Fukushima accident (i.e. what was learnt from the accident and what actions are being taken to address those lessons). The information request included a clear statement regarding the objective of the information request and specific instructions concerning sources of lessons learnt (see Chapter 3 of this report) but these may have been insufficient to overcome the pre-existing focus on lessons learnt from the accident itself.
- Documentation of actions taken in response to the accident focused on the final outcome and not on the resolution of interim challenges. As a result, the type of insights the task group sought to gather had not been formally captured by the respondents to the Phase 2 request and therefore could not be readily shared using existing documentation.
- Licensees may have been apprehensive about the perceptions or regulatory attention that could result from the identification of challenges experienced implementing the post-Fukushima actions.
- Nuclear plant licensees, industry organisations, and regulatory authorities dedicated substantial resources to the development and implementation of post-Fukushima actions. There may have been few lessons learnt as these efforts were effective in minimising the incidence of unforeseen challenges during implementation.
- New capabilities that have been put in place in response to the Fukushima accident have not been sufficiently tested, either through formal validation methods or by exercising them in drills or training, to expose the HOF challenges.

As noted earlier in this report, there are practical and safety limitations on how well such actions can be validated.

Although it remains unclear whether these or other factors may have contributed to the predominant focus on the actions taken, rather than the lessons learnt in the process, the possibility remains that few lessons learnt were reported as there was limited licensee experience testing these new capabilities in drills or exercises when they received the solicitation for information. Consistent with this view, through their review of the Phase 1 submissions, the task group observed that whereas training for extreme external events and severe accidents may be performed in some cases on an annual basis, requirements and guidance concerning the frequency of related drills and exercises, where specified, typically had longer periodicities (e.g. three years), commensurate with these being low probability events. Accordingly, the working group proposes that assessments of the safety enhancement achieved by putting in place mitigation capabilities for extreme external events and severe accidents should continue to be tempered by the extent to which the ability of personnel to implement these capabilities has been demonstrated under the conditions that they will be required.

Given the content of the Phase 2 submissions, the task group expects the information provided in response to the Phase 2 request will likely be of more value to those seeking to understand the range of challenges presented by extreme external events and severe accidents, and the diversity of approaches that operating companies have implemented to address those challenges. Such information can nonetheless be of substantial value as it points to issues and options that one may have not previously considered. Regarding how well these approaches have effectively addressed HOF considerations, readers are likely to find that additional information would be necessary to understand the extent to which the measures were verified against applicable HOF standards and how the measures were validated with respect to their ability to support intended performance outcomes under the range of conditions for which they are intended.

Of the limited HOF implementation experience reported in response to the Phase 2 information request, that experience is related to:

1. Implementation of diesel generator as alternate power supplies (see Appendix B Lessons Learnt: CZ-04, SP-01, and US-02).
2. Analysis/validation of mitigation strategies (see Appendix B Lessons Learnt: CZ-04, SP-01, and US-01).

3. Analysis/validation of minimum staffing (see Appendix B Lessons Learnt: FR-01).
4. Remote automated gamma monitoring (see Appendix B Lessons Learnt: CA-05).

Although these examples provide an insufficient basis to infer the areas where human performance challenges might be most prevalent in the implementation of post-Fukushima actions, the importance of alternate power supplies to many mitigation strategies and the broad applicability of validation practices to ensure that intended outcomes can be achieved suggest that these may be areas on which to focus future monitoring/assessment efforts.

## Chapter 4. Conclusions

The summaries and questionnaire responses submitted by national nuclear regulatory authorities in response to the Phase 1 information request, and compiled in Appendix A, provide a compendium of the important steps that have been taken to substantially enhance the ability of plant operators to mitigate the impact of extreme external events and severe accidents on nuclear facilities and public health and safety. These steps mainly comprise the provision of new, additional, or improved facilities, equipment, supplies, and strategies that support, but do not supplant, the roles and responsibilities of plant personnel in responding to such events. Whereas most post-Fukushima actions have been previously described from various engineering, safety, and regulatory perspectives, this WGHOF effort has focused on the human and organisational factors and the implications and challenges associated with these actions.

The Phase 1 submissions confirm that plant personnel continue to have important, often critical, roles in mitigating extreme external events and managing severe accidents. These roles cover the gamut from initial accident assessment to event mitigation, off-site, and long-term event response. Whether the safety enhancements will provide their full intended benefits will depend on the extent to which plant operators have accounted for, and adequately addressed, the challenges that these events pose to effective and reliable human and organisational performance. It is evident from the Phase 1 submissions that many of the actions were implemented with specific consideration of such challenges (e.g. response strategies were formalised in guidelines and procedures to aid decision making, connections for portable equipment were colour coded to reduce the cognitive burden of determining appropriate connections; required local actions for mitigation strategies were limited to areas with protection from external hazards). Unfortunately, the Phase 2 information request yielded limited information regarding the validation of the measures that operators put in place. The lessons learnt included in some instances limited initial validations, suggesting that more insights will come to light as licensees implement their periodic training and testing activities.

The implementation actions summarised in the Phase 1 responses, and described in greater detail in the Phase 2 submissions, show that each country typically addressed three major aspects of response to extreme external events and severe accidents: (1) analysis and decision support (e.g. assessment of plume pathways), (2) mitigation strategies and equipment (e.g. portable generators, pumps, and procedures/strategies for their use), and (3) command, control, and communication capabilities (e.g. improvements to command centres, communications equipment, and assignment of decision and response functions). Although each aspect contributes uniquely to response effectiveness, there are often substantive and important interdependencies between these aspects of accident response. In sum, an effective response to extreme external events and severe accidents largely depends on a co-ordinated and integrated response by a relatively large, and to some extent diverse, group of human actors (e.g. control room operators, field operators/technical, technical support centre staff, local authorities off-site organisations, and regional response centres) who are working under conditions that at minimum are novel (i.e. rare) and likely include mental and/or environmental stressors.

The mitigation of extreme external events and management of severe accidents at nuclear facilities can thus be viewed as relatively complex systems of individuals, technologies, and organisations in which the human element is essential to mission success. Such a “systems” view has two important implications. First, it helps us to more fully appreciate and consider the effects that degraded human performance in one sphere or “subsystem” of the response can have on other elements of the response. Delays or errors in the human actions required for event mitigation, including decision making, can ripple through the system, resulting in desynchronisation of the various response organisations, further degradation of the plant state, and loss of available response options. Validation of the ability to reliably perform such required

actions is therefore central to ensuring the overall system can successfully respond to such events.

The second implication of viewing mitigation of extreme external events and management of severe accidents as a complex system is that it reminds us that in nearly every complex system, in addition to those subsystem interactions that are present by design to achieve intended outcomes, there are often unanticipated interactions that can have deleterious consequences. This is true at least for the case of new, or newly modified systems. “New” or “newly modified” are descriptors that can reasonably be applied to the many new capabilities that have been developed and put in place for event response post-Fukushima. It follows that in addition to validation of elemental human actions required for event response, tests of event response systems as a whole are important to ensure that the subsystems are capable of functioning together, and that the human and organisational elements of the response do not reveal the functional equivalents (e.g. “sneak circuits”, signal distortion, sequencing errors, inadequate bandwidth) that often plague the integration of technological systems.

This view of mitigation of extreme external events and management of severe accidents leads the task group to assert the importance of validating required human actions, but with the understanding and caveat that such validations can be complex and resource-intensive undertakings. Additionally, the notion of acceptance criteria for “successful” validation is not a simple matter.

Validation of time-limited required manual actions might appear to be relatively straightforward to carry out until the context of extreme external events and severe accidents is considered. From the human performance perspective, these contexts introduce the need to consider testing human performance under psychological and environmental conditions that might be viewed as unsafe or unethical to reproduce with fidelity in a simulated validation environment. From a regulatory/licensing perspective, such events are typically considered to be outside the design basis of the facilities, causing them to be unbounded conditions. As a consequence, even if it is determined that validation can be performed under more realistic and extreme conditions, there can be debate as to what degree of psychological or environmental stressor (e.g. flood water depth, temperature, debris field) is sufficient to satisfy validation objectives.

Considering validations of the overall response to extreme external events and severe accidents, added to the challenges described above is the sheer magnitude of exercises required to evaluate and demonstrate integrated response capabilities. Engaging multiple on-site and off-site organisations in simulations of events, which can span days, is an expensive and time-consuming undertaking in both planning and implementation, and must be conducted on a frequency and in a manner that justifies the safety benefits.

These acknowledged challenges to validating human and organisational responses to extreme external events and severe accidents should not, however, be taken as basis for dismissing such validation efforts as of limited value or impractical, but rather call for innovative thinking and collective action as discussed in Chapter 5.

## Chapter 5. Recommendations

As observed in the NEA report, *Five Years After the Fukushima Daiichi Accident* (NEA, 2016b), and reiterated in the NEA report, *Fukushima Daiichi Nuclear Power Plant Accident, Ten Years On: Progress, Lessons, and Challenges* (NEA, 2021), continuous and innovative progress is fundamental to ensuring safety, even where many improvements have been made. Lessons learnt through operating experience and research will require continued attention. This is particularly true for complex areas such as the human aspects of nuclear safety as reflected in safety culture, training and organisational factors. Constant vigilance and effort are needed at the national and international levels.

The WGHOFF initiative documented in this report was undertaken to support such innovative and continuous progress. The effort had two primary objectives: (1) gather the human and organisational factors (HOF) lessons learnt (positive and negative) that are being gained while implementing the actions that many regulatory authorities and nuclear facility operators around the world are taking to strengthen their ability to respond to events like that experienced at Fukushima; and (2) share these implementation lessons learnt broadly (e.g. with nuclear facility operating companies, technical support organisations, research institutions, and regulatory authorities) so that they can be used to facilitate and enhance these efforts going forward. To that end the WGHOFF offers the following recommendations:

- Appendix A to this report is a compendium of summaries from regulatory authorities in seven countries that describes the breadth and diversity of post-Fukushima actions that have been undertaken, with an emphasis on the human and organisational aspects. The summaries also point to the applicable requirements and guidelines. Each summary is accompanied by questionnaire responses that draw the relationship between the specific actions described in the summaries and each of ten topical areas concerning human and organisational factors. Readers are encouraged to explore the contents of this appendix and use the information as a resource (e.g. identification of alternative tools, methods, and strategies) for informing their current and future efforts pertaining to the mitigation of extreme events and management of severe accidents. Additionally, this report proposes a systemic human, technology and organisation (HTO) approach to implementing post-Fukushima actions so that the interactions of humans, technology and organisational factors are considered in an integrated manner, as it could prove useful in gaining the full benefit of these efforts.
- Appendix B to this report is a compendium of 40 lesson learnt submissions describing specific implementation activities that have been undertaken and the insights gained in the process. These submissions bring to life the actions and requirements described in Appendix A, including some of the challenges that were encountered and overcome in the process. Readers are encouraged to explore the contents of Appendix B to gain a deeper understanding of the material presented in Appendix A, consider the human and organisational factors of response to extreme external events and severe accidents, and assess the applicability of the lessons learnt to their efforts and capabilities for event mitigation and accident management.
- As described in Chapter 4, although many technological enhancements have been made to improve the mitigation of extreme external events and management of severe accidents at nuclear facilities, responses to these events rely in large measure on human actors performing under challenging conditions. Validations of required actions at the elemental and integrated level are fundamental to ensure that the intended safety benefits of post-Fukushima actions for event mitigation and accident management have been achieved and will be maintained. Chapter 4 also identified specific challenges to

conducting such validations. This report encourages initiatives that target these challenges with the aim of developing innovative and practical solutions and sharing these solutions broadly. Efforts are recommended to enhance validation for such actions at both the elemental and integrated levels.

- Lastly, this effort towards aggregating and disseminating the HOF lessons learnt during implementation of post-Fukushima actions should be viewed as a modest first step. The challenge remains of accelerating learning in managing the human and organisational factors of complex and challenging event mitigation and accident management activities. This report encourages initiatives, such as the effort documented above, that facilitate the identification and broad dissemination of insights and best practices for HOF aspects of mitigating extreme external events and the management of severe accidents.



## References

- CNSC (2011), *CNSC Fukushima Task Force Report*, INFO-0824, CNSC, Ottawa, <http://nuclearsafety.gc.ca/eng/resources/fukushima/fukushima-canada-action-plan.cfm>.
- Laarni, J. (2019). “Cognitive Heuristics and biases in process control and maintenance work”, *Proceeding of the 11<sup>th</sup> International Topical Conference on Nuclear Plant Instrumentation, Control & Human Interface Technologies*, American Nuclear Society, Florida.
- NEA (2021), *Fukushima Daiichi Nuclear Power Plant Accident, Ten Years On: Progress, Lessons and Challenges*, OECD Publishing, Paris, [www.oecd-nea.org/jcms/pl\\_56742/fukushima-daiichi-nuclear-power-plant-accident-ten-years-on](http://www.oecd-nea.org/jcms/pl_56742/fukushima-daiichi-nuclear-power-plant-accident-ten-years-on).
- NEA (2016), *Five Years after the Fukushima Daiichi Accident: Nuclear Safety Improvements and Lessons Learnt*, OECD Publishing, Paris, [www.oecd-nea.org/jcms/pl\\_14978/five-years-after-the-fukushima-daiichi-accident](http://www.oecd-nea.org/jcms/pl_14978/five-years-after-the-fukushima-daiichi-accident).
- NEA (2015), “Human Performance under Extreme Conditions With Respect to a Resilient Organisation - Proceedings of a CSNI International Workshop, Brugg, Switzerland, 24-26 February 2014”, NEA/CSNI/R(2015)16, OECD Publishing, Paris, [www.oecd-nea.org/jcms/pl\\_19668/human-performance-under-extreme-conditions-with-respect-to-a-resilient-organization-proceedings-of-a-csni-international-workshop-brugg-switzerland-24-26-february-2014](http://www.oecd-nea.org/jcms/pl_19668/human-performance-under-extreme-conditions-with-respect-to-a-resilient-organization-proceedings-of-a-csni-international-workshop-brugg-switzerland-24-26-february-2014).
- NRC (2020), “Flex Diesel Generator Operational Challenges”, Information Notice 2020-02, NRC, Washington DC, [www.nrc.gov/docs/ML2019/ML20196L822.pdf](http://www.nrc.gov/docs/ML2019/ML20196L822.pdf).
- NRC (2011), *Recommendations for Enhancing Reactor Safety in the 21<sup>st</sup> Century: The Near-Term Task Force Review of Insights from the Fukushima Daiichi Accident*, NRC, Washington DC, [www.nrc.gov/docs/ML1125/ML112510271.pdf](http://www.nrc.gov/docs/ML1125/ML112510271.pdf).
- NRC (1994a), *The Impact of Environmental Conditions on Human Performance*, NUREG/CR-5680, NRC, Washington DC, [www.nrc.gov/docs/ML0704/ML070460030.pdf](http://www.nrc.gov/docs/ML0704/ML070460030.pdf).
- NRC (1994b), *The Effects of Stress on Nuclear Power Plant Operational Decision Making and Training Approaches to Reduce Stress Effects*, NUREG/CR-6127, NRC, Washington DC, [www.nrc.gov/docs/ML1025/ML102530314.pdf](http://www.nrc.gov/docs/ML1025/ML102530314.pdf).
- UJV Rez. (2018), “Safety analysis of recovery of power supply using MDG”, Z-5064-T, UJV Rez., Husinec.



**Appendix A: Regulatory Authority Responses to the Phase 1  
Information Request - Summaries of Actions Taken and  
Questionnaire Responses Regarding Human and Organisational  
Factors Addressed by these Actions**

This annex is available online: [www.oecd-nea.org/7578-annex1](http://www.oecd-nea.org/7578-annex1)



Appendix B: **Responses to Phase 2 Information Request –  
Human and Organisational Factors Lessons Learnt Implementing  
Post-Fukushima Actions**

This annex is available online: [www.oecd-nea.org/7578-annex2](http://www.oecd-nea.org/7578-annex2)

## NEA PUBLICATIONS AND INFORMATION

The full catalogue of publications is available online at [www.oecd-nea.org/pub](http://www.oecd-nea.org/pub).

In addition to basic information on the Agency and its work programme, the NEA website offers free downloads of hundreds of technical and policy-oriented reports. The professional journal of the Agency, *NEA News* – featuring articles on the latest nuclear energy issues – is available online at [www.oecd-nea.org/nea-news](http://www.oecd-nea.org/nea-news).

An NEA monthly electronic bulletin is distributed free of charge to subscribers, providing updates of new results, events and publications. Sign up at [www.oecd-nea.org/tools/maillinglist/register](http://www.oecd-nea.org/tools/maillinglist/register).

Visit us on LinkedIn at [www.linkedin.com/company/oecd-nuclear-energy-agency](http://www.linkedin.com/company/oecd-nuclear-energy-agency) or follow us on Twitter @OECD\_NEA.



# Post-Fukushima Action Implementation at Nuclear Installations

This report compiles and shares some of the lessons learnt from implementing post-Fukushima actions related to human and organisational factors (HOF), including at nuclear facility operating companies, technical support organisations, research institutions, and regulatory authorities.

It summarises a two-phase information-gathering exercise, overseen by the NEA Working Group on Human and Organisational Factors, about the requirements and guidelines that countries and nuclear licensees have adopted since the accident.

The report discusses the central role of human and organisational performance in mitigating extreme external events and the management of severe accidents. It addresses the importance of validating the ability to perform these actions, and the challenges associated with performing such validations with fidelity to the conditions likely to be present during such events. The report concludes by providing four key recommendations that seek to promote greater sharing of information and the identification of best practices.